

An Introduction to Neutron and X-Ray Scattering: SANS, SAXS & Reflectometry

by

Roger Pynn

Indiana University and Oak Ridge National Lab

With thanks to various friends for allowing me to use their materials:
especially Jen Als-Nielsen, Mike Fitzsimmons & Sunhil Sinha

Small Angle Scattering (SANS or SAXS) Is Used to Measure Large Objects (~10 nm to ~1 μm)

Recall that :

$$\vec{Q} = \vec{k}' - \vec{k}_0 = 2k_0 \sin \theta \quad \text{for elastic scattering}$$

and that

$$\lambda = 2\pi / k = 2\pi / (Q / 2 \sin \theta) = 4\pi \sin \theta / Q$$

so we can rewrite Bragg's law $\lambda = 2d \sin \theta$ as

$$d = 2\pi / Q \quad \text{or for small } \theta \quad d \approx \lambda / 2\theta$$

i.e. small Q => large length scales

Scattering at small angles probes large length scales

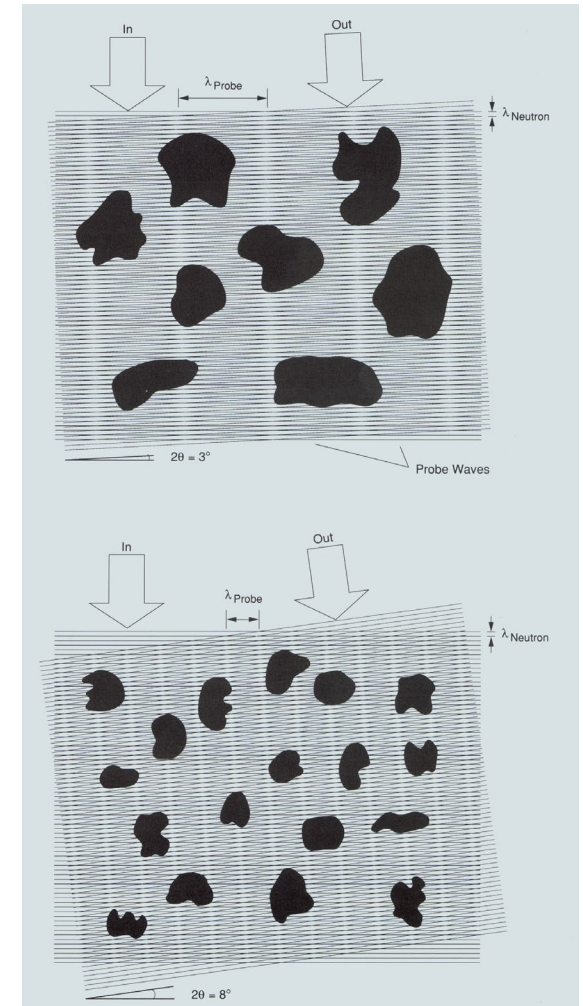

Typical scattering angles for SANS are $\sim 0.3^\circ$ to 5°

Typical SANS/SAXS Applications

- **Biology**
 - Organization of biomolecular complexes in solution
 - Conformation changes affecting function of proteins, enzymes, protein/DNA complexes, membranes etc
 - Mechanisms and pathways for protein folding and DNA supercoiling
- **Polymers**
 - Conformation of polymer molecules in solution and in the bulk
 - Structure of microphase separated block copolymers
 - Factors affecting miscibility of polymer blends
- **Chemistry**
 - Structure and interactions in colloid suspensions, microemulsions, surfactant phases etc
 - Mechanisms of molecular self-assembly in solutions

Biological Applications of SANS

- Studying Biological Macromolecules in Solution
 - Proteins
 - Nucleic Acids
 - Protein-nucleic acid complexes
 - Multi-subunit protein complexes
 - Membranes and membrane components
 - Protein-lipid complexes
- One of the issues with studying bio-molecules is that most contain H which gives a large, constant background of incoherent scattering. To avoid this:
 - Use D₂O instead of water as a fluid for suspension
 - May need to deuterate some molecular components

The Concept of SANS & SAXS

- Measure scattering at small angles & azimuthally average for isotropic samples

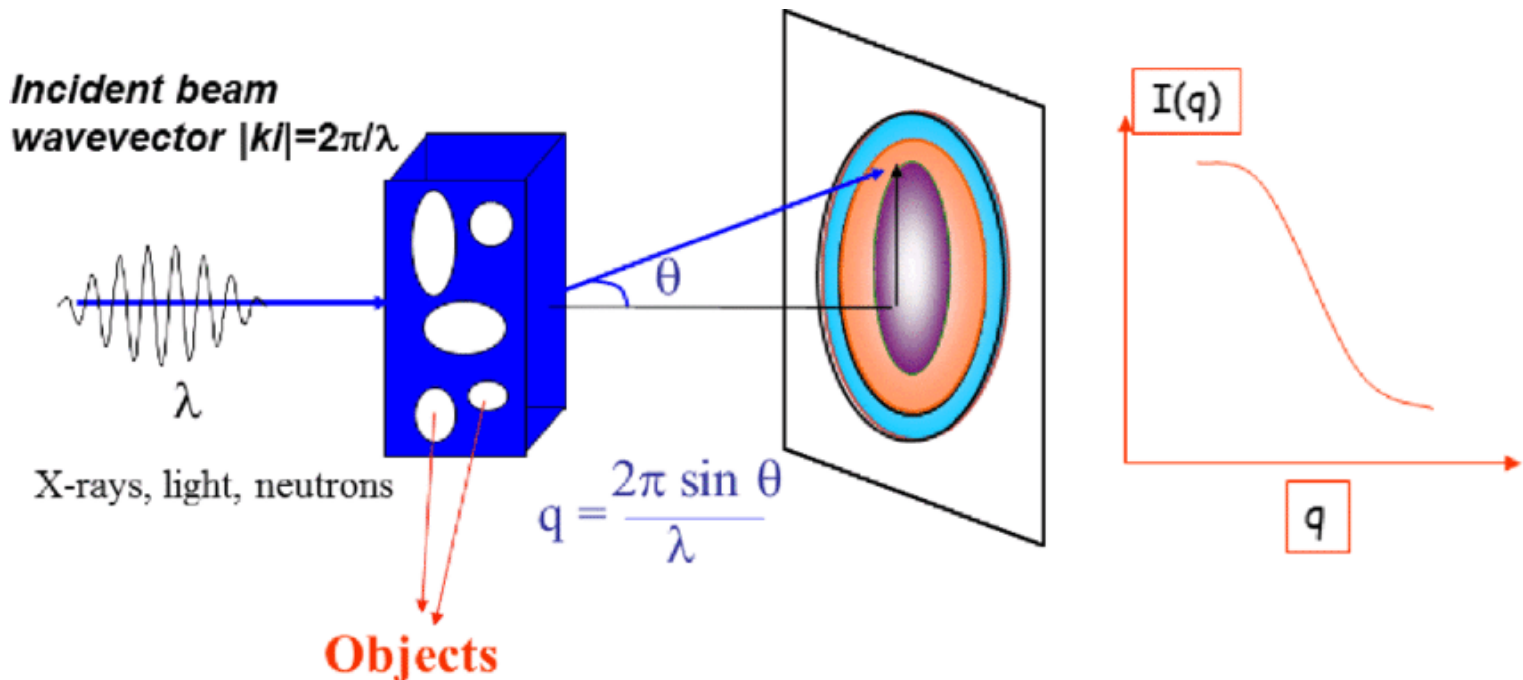

SANS in Practice

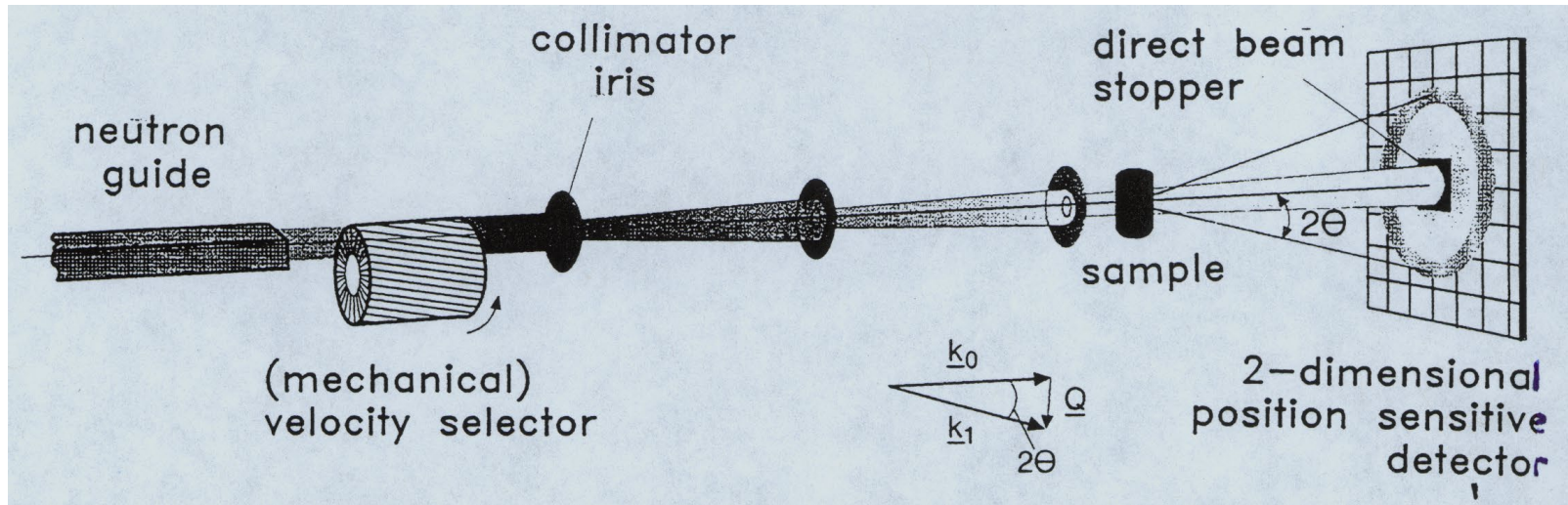

1. Need a way to determine neutron wavelength
 - Velocity selector or TOF
2. To measure the scattering angle accurately, we need to define the incident beam trajectory very well
3. Increase scattering by increasing lateral size of sample
 - (2) & (3) \Rightarrow the instrument has to be long (40m max for D11 at ILL)

The NIST 30m SANS Instrument Under Construction



Where Does SANS Fit As a Structural Probe?

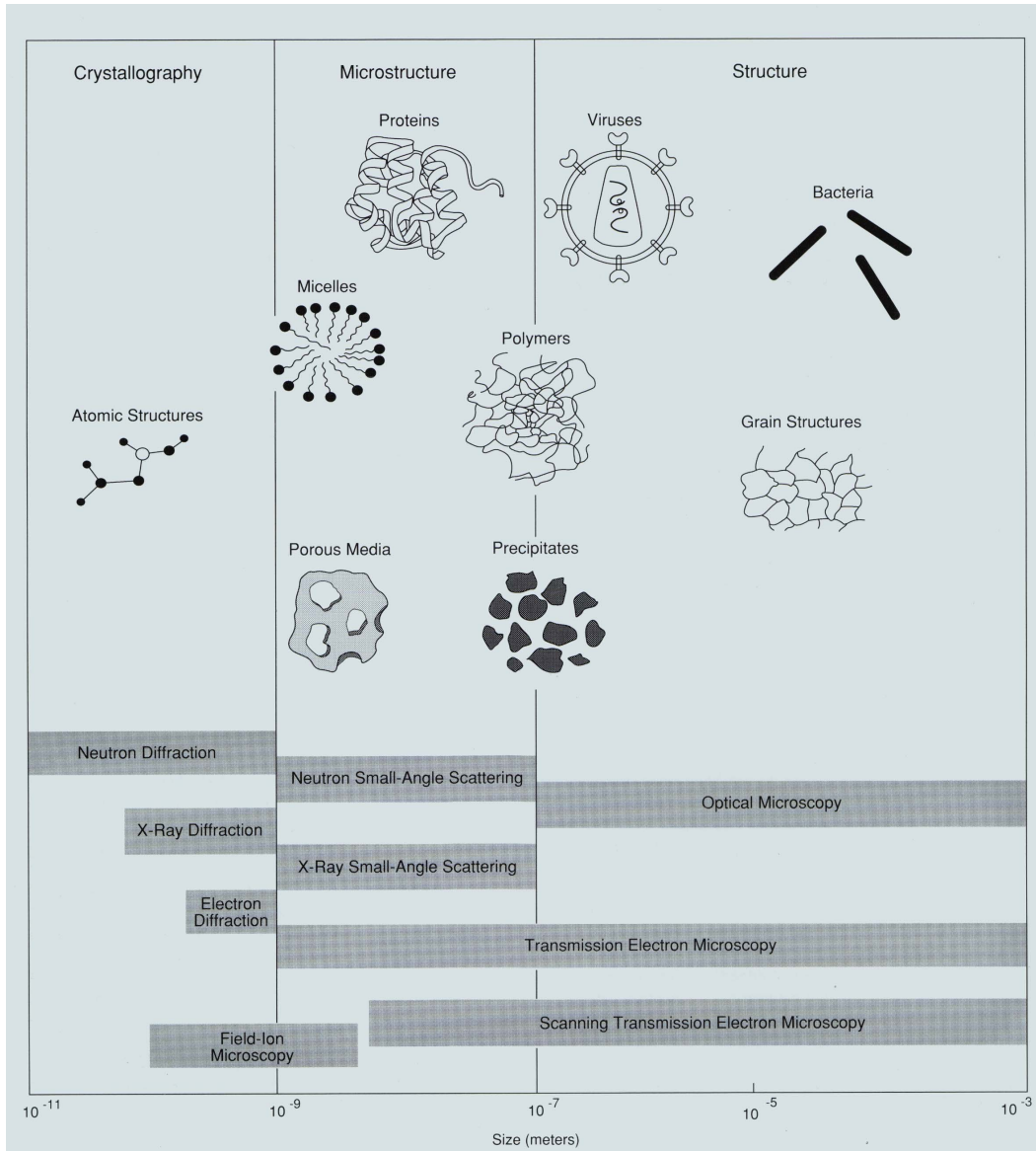

- SANS resolves structures on length scales of 1 – 1000 nm
- Neutrons can be used with bulk samples (1-2 mm thick)
- SANS is sensitive to light elements such as H, C & N
- SANS is sensitive to isotopes such as H and D

Instrumental Resolution for SANS/SAXS

$$Q = \frac{4\pi}{\lambda} \sin \theta \Rightarrow \left\langle \frac{\delta Q^2}{Q^2} \right\rangle = \left\langle \frac{\delta \lambda^2}{\lambda^2} \right\rangle + \left\langle \frac{\cos^2 \theta \cdot \delta \theta^2}{\sin^2 \theta} \right\rangle$$

For SANS, $(\delta \lambda / \lambda)_{rms} \sim 5\%$ and θ is small, so $\left\langle \frac{\delta Q^2}{Q^2} \right\rangle = 0.0025 + \left\langle \frac{\delta \theta^2}{\theta^2} \right\rangle$

For equal source - sample & sample - detector distances of L and equal apertures at source and sample of h , $\delta \theta_{rms} = \sqrt{5/12} h/L$.

The smallest value of θ is determined by the direct beam size: $2\theta_{min} \sim 1.5h/L$

At this value of θ , angular resolution dominates and

$$\delta Q_{rms} \sim (\delta \theta_{rms} / \theta_{min}) Q_{min} \sim \delta \theta_{rms} 4\pi / \lambda \sim (2\pi / \lambda) h / L$$

The largest observable object is $\sim 2\pi / \delta Q_{rms} \sim \lambda L / h$. 

This achieves a maximum of about $5 \mu\text{m}$ at the ILL 40 m SANS instrument using 15 \AA neutrons.

Note that at the largest values of θ , set by the detector size and distance from the sample, wavelength resolution dominates.

The Fermi Pseudo-Potential for Neutrons

$$\frac{d\sigma}{d\Omega} = \frac{1}{\Phi} \frac{1}{d\Omega} \sum_{\vec{k}' \text{ in } d\Omega} W_{\vec{k} \rightarrow \vec{k}'}, \quad \text{where the sum is over probabilities of all transitions}$$

$$\text{By Fermi's Golden Rule: } \sum_{\vec{k}' \text{ in } d\Omega} W_{\vec{k} \rightarrow \vec{k}'} = \frac{2\pi}{\hbar} \rho_{\vec{k}'} \left| \langle \vec{k}' | V | \vec{k} \rangle \right|^2 = \frac{2\pi}{\hbar} \rho_{\vec{k}'} \frac{1}{Y^2} \left| \int_V V(\vec{r}) e^{i(\vec{k}-\vec{k}') \cdot \vec{r}} d\vec{r} \right|^2$$

where $\rho_{\vec{k}'}$ is # of momentum states in $d\Omega$, per unit energy, for neutrons in state \vec{k}'

Using standard "box normalization", the volume per k state is $(2\pi)^3 / Y$ where $Y = \text{box volume}$

$$\text{Final neutron energy is } E' = \frac{\hbar^2 k'^2}{2m} \Rightarrow dE' = \frac{\hbar^2 k' dk'}{m} \quad \text{so}$$

$$\rho_{k'} dE' = \text{number of wavevector states in volume } k'^2 dk' d\Omega = \frac{Y}{(2\pi)^3} k'^2 dk' d\Omega$$

$$\text{i.e. } \rho_{\vec{k}'} = \frac{\text{number of wavevector states}}{dE'} = \frac{Y}{(2\pi)^3} k' \frac{m}{\hbar^2} d\Omega$$

$$\text{Further, } \Phi = \text{incident flux} = \text{density} \times \text{velocity} = \frac{1}{Y} \frac{\hbar}{m} k$$

$$\text{So, } \frac{d\sigma}{d\Omega} = \frac{Y}{k} \frac{m}{\hbar} \frac{1}{d\Omega} \frac{2\pi}{\hbar} \frac{Y}{(2\pi)^3} k' \frac{m}{\hbar^2} d\Omega \left| \langle \vec{k}' | V | \vec{k} \rangle \right|^2 = \left(\frac{m}{2\pi\hbar^2} \right)^2 \left| \int V(\vec{r}) e^{i(\vec{k}-\vec{k}') \cdot \vec{r}} d\vec{r} \right|^2$$

Fermi pseudopotential

$$\text{so } V(\vec{r}) = \frac{2\pi\hbar^2}{m} b \delta(\vec{r})$$

Use $V(r)$ to Calculate the Refractive Index for Neutrons

The nucleus - neutron potential is given by : $V(\vec{r}) = \frac{2\pi\hbar^2}{m} b\delta(\vec{r})$ for a single nucleus.

So the average potential inside the medium is : $\bar{V} = \frac{2\pi\hbar^2}{m} \rho$ where $\rho = \frac{1}{\text{volume}} \sum_i b_i$

ρ is called the nuclear **Scattering Length Density (SLD)** - used for SANS & reflectometry

The kinetic (and total) energy of neutron in vacuum is $E = \frac{\hbar^2 k_0^2}{2m}$

Inside the medium the total energy is $\frac{\hbar^2 k^2}{2m} + \bar{V}$

Conservation of energy gives $\frac{\hbar^2 k_0^2}{2m} = \frac{\hbar^2 k^2}{2m} + \bar{V} = \frac{\hbar^2 k^2}{2m} + \frac{2\pi\hbar^2}{m} \rho$ or $k_0^2 - k^2 = 4\pi\rho$

Since $k/k_0 = n = \text{refractive index}$ (by definition), and ρ is very small ($\sim 10^{-6} \text{ \AA}^{-2}$) we get :

$$n = 1 - \lambda^2 \rho / 2\pi$$

Since generally $n < 1$, neutrons are externally reflected from most materials.

Why do we Care about the Refractive Index?

- When the wavevector transfer Q is small, the phase factors in the cross section do not vary much from nucleus to nucleus & we can use a continuum approximation
- We can use all of the apparatus of optics to calculate effects such as:
 - External reflection from single surfaces (for example from guide surfaces)
 - External reflection from multilayer stacks (including supermirrors)
 - Focusing by (normally) concave lenses or Fresnel lenses
 - The phase change of the neutron wave through a material for applications such as interferometry or phase radiography
 - Fresnel edge enhancement in radiography

Refractive Index for x-rays

$$n = 1 - \delta + i\beta$$

$$\text{where } \delta = \frac{2\pi\rho_a f^0(0)r_0}{k^2} \quad \text{and} \quad \beta = \frac{\mu}{2k}$$

ρ_a is the atomic number density; k is the x - ray wavevector

μ is the absorption coefficient (i.e. intensity decreases as $e^{-\mu z}$)

The wave outside the medium is e^{ikz} ; inside the medium it is e^{inkz}

Note the we can also write :

$$n \equiv 1 - \frac{2\pi\rho_a r_0}{k^2} \{f^0(0) + f' + if''\} \quad \text{with} \quad \beta = -\left[\frac{2\pi\rho_a r_0}{k^2}\right] f''$$

$$\text{so } f'' = -\left[\frac{k^2}{2\pi\rho_a r_0}\right] \beta = -\left[\frac{k^2}{2\pi\rho_a r_0}\right] \frac{\mu}{2k} = -\left(\frac{k}{4\pi r_0}\right) \sigma_a \quad \text{because} \quad \mu = \rho_a \sigma_a$$

Scattering Length Density

- Remember $\frac{d\sigma}{d\Omega} = b_{coh}^2 \left\langle \left| \int d\vec{r} \cdot e^{-i\vec{Q}\cdot\vec{r}} n_{nuc}(\vec{r}) \right|^2 \right\rangle$
- What happens if Q is very small?
 - The phase factor will not change significantly between neighboring atoms
 - We can average the nuclear scattering potential over length scales $\sim 2\pi/10Q$
 - This average is called the scattering length density and denoted $\rho(\vec{r})$
- How do we calculate the SLD?
 - Easiest method: go to www.ncnr.nist.gov/resources/sldcalc.html
 - By hand: let us calculate the scattering length density for quartz – SiO₂
 - Density is 2.66 gm.cm⁻³; Molecular weight is 60.08 gm. mole⁻¹
 - Number of molecules per Å³ = N = 10⁻²⁴(2.66/60.08)*N_{avagadro} = 0.0267 molecules per Å³
 - SLD=Σb/volume = N(b_{Si} + 2b_O) = 0.0267(4.15 + 11.6) 10⁻⁵ Å⁻² = 4.21 x10⁻⁶ Å⁻²
- A uniform SLD causes scattering only at Q=0; variations in the SLD cause scattering at finite values of Q

SLD Calculation

- www.ncnr.nist.gov/resources/sldcalc.html
- Need to know chemical formula and density

Enter → Compound
 → Density (g/cm³)

Not relevant for SLD → Wavelength (Å)

C6H12
0.86
6
Calculate

Neutron SLD -3.07E-7 (Å⁻²)

X-ray values → Cu Ka SLD 8.34E-6 +9.36E-9i (Å⁻²)

→ Mo Ka SLD 8.33E-6 +2.08E-9i (Å⁻²)

Background → Neutron Inc. XS 5.93; 33.4 (cm⁻¹)

Neutron Abs. XS 0.0823 (cm⁻¹)

Determine best sample thickness → Neutron 1/e length 0.166 (cm)

Note units of the cross section – this is cross section per unit volume of sample

SANS Measures Particle Shapes and Inter-particle Correlations

$$\frac{d\sigma}{d\Omega} = \langle b \rangle^2 \int_{\text{space}} d^3r \int_{\text{space}} d^3r' n_N(\vec{r}) n_N(\vec{r}') e^{i\vec{Q} \cdot (\vec{r} - \vec{r}')} \\ = \int_{\text{space}} d^3R \int_{\text{space}} d^3R' \langle n_P(\vec{R}) n_P(\vec{R}') \rangle e^{i\vec{Q} \cdot (\vec{R} - \vec{R}')} \left\langle \left| (\rho - \rho_0) \int_{\text{particle}} d^3x e^{i\vec{Q} \cdot \vec{x}} \right|^2 \right\rangle_{\text{orientation}}$$

$$\frac{d\sigma}{d\Omega} = (\rho - \rho_0)^2 |F(\vec{Q})|^2 V_p^2 N_P \int_{\text{space}} d^3R G_P(\vec{R}) e^{i\vec{Q} \cdot \vec{R}}$$

where G_P is the particle - particle correlation function (the probability that there is a particle at \vec{R} if there's one at the origin) and $|F(\vec{Q})|^2$ is the particle form factor :

$$|F(\vec{Q})|^2 = \frac{1}{V_p^2} \left\langle \left| \int_{\text{particle}} d^3x e^{i\vec{Q} \cdot \vec{x}} \right|^2 \right\rangle_{\text{orientation}}$$

These expressions are the same as those for nuclear scattering except for the addition of a form factor that arises because the scattering is no longer from point-like particles

Scattering from Independent Particles

Scattered intensity per unit volume of sample = $I(\vec{Q}) = \frac{1}{V} \frac{d\sigma}{d\Omega} = \frac{1}{V} \left\langle \left| \int \rho(\vec{r}) e^{i\vec{Q}\cdot\vec{r}} d\vec{r} \right|^2 \right\rangle$

For identical particles

$$I(Q) = \frac{N}{V} (\rho_p - \rho_0)^2 V_p^2 \left\langle \left| \frac{1}{V_{p \text{ particle}}} \int e^{i\vec{Q}\cdot\vec{r}} d\vec{r} \right|^2 \right\rangle$$

contrast factor

particle form factor $|F(\vec{Q})|^2$

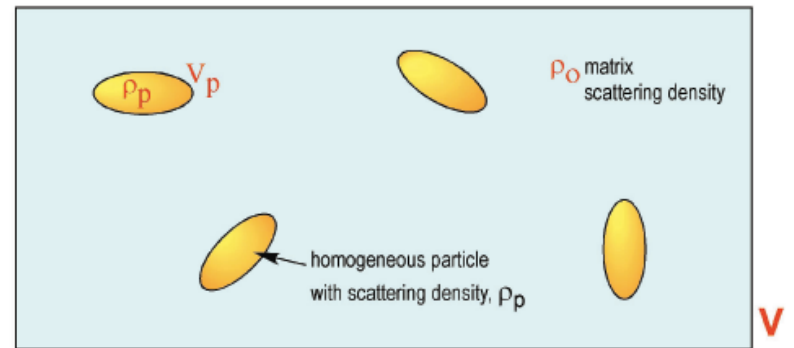

Note that $I(0) = \frac{N}{V} (\rho_p - \rho_0)^2 V_p^2$

Particle concentration $c = NV_p / V$ and particle molecular weight $M_w = \rho V_p N_A$ where ρ is the particle mass density and N_A is Avagadro's number

so $I(0) = \frac{cM_w}{\rho N_A} (\rho_p - \rho_0)^2$ provides a way to find the particle molecular weight

Scattering for Spherical Particles

The particle form factor $|F(\vec{Q})|^2 = \left| \int_V d\vec{r} e^{i\vec{Q}\cdot\vec{r}} \right|^2$ is determined by the particle shape.

For a sphere of radius R, F(Q) only depends on the magnitude of Q :

$$F_{sphere}(Q) = 3V_0 \left[\frac{\sin QR - QR \cos QR}{(QR)^3} \right] \equiv \frac{3V_0}{QR} j_1(QR) \rightarrow V_0 \text{ at } Q = 0$$

Thus, as $Q \rightarrow 0$, the total scattering from an assembly of uncorrelated spherical particles [i.e. when $G(\vec{r}) \rightarrow \delta(\vec{r})$] is proportional to the square of the particle volume times the number of particles.

For elliptical particles

replace R by :

$$R \rightarrow (a^2 \sin^2 \vartheta + b^2 \cos^2 \vartheta)^{1/2}$$

where ϑ is the angle between

the major axis (a) and \vec{Q}

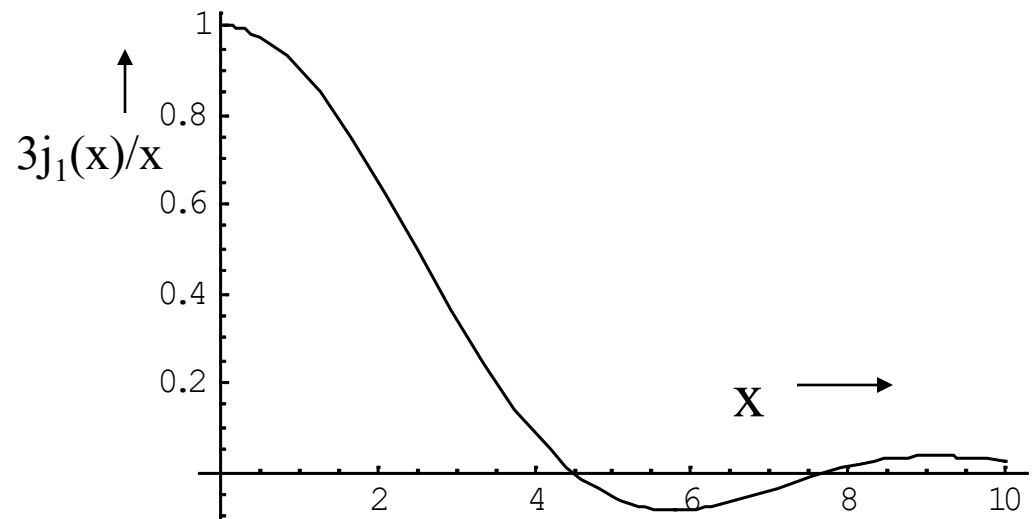

Radius of Gyration Is the Particle “Size” Usually Deduced From SANS Measurements

If we measure \vec{r} from the centroid of the particle and expand the exponential in the definition of the form factor at small Q :

$$F(Q) = \int_V d\vec{r} e^{i\vec{Q}\cdot\vec{r}} \approx V_0 + i \int_V \vec{Q}\cdot\vec{r} d^3r - \frac{1}{2} \int_V (\vec{Q}\cdot\vec{r})^2 d^3r + \dots$$
$$= V_0 \left[1 - \frac{Q^2}{2} \frac{\int_0^\pi \cos^2 \theta \sin \theta d\theta \int_{V_0} r^2 d^3r}{\int_0^\pi \sin \theta d\theta \int_{V_0} d^3r} + \dots \right] = V_0 \left[1 - \frac{Q^2 r_g^2}{6} + \dots \right] \approx V_0 e^{-\frac{Q^2 r_g^2}{6}}$$

where r_g is the radius of gyration is $r_g = \sqrt{\int_V R^2 d^3r / \int_V d^3r}$. It is usually obtained from a fit to SANS data at low Q (in the so - called Guinier region) or by plotting $\ln(\text{Intensity})$ v Q^2 . The slope of the data at the lowest values of Q is $r_g^2/3$. It is easily verified that the expression for the form factor of a sphere is a special case of this general result.

Determining Particle Size From Dilute Suspensions

- Particle size is usually deduced from dilute suspensions in which inter-particle correlations are absent
- In practice, instrumental resolution (finite beam coherence) will smear out minima in the form factor
- This effect can be accounted for if the spheres are mono-disperse
- For poly-disperse particles, maximum entropy techniques have been used successfully to obtain the distribution of particles sizes

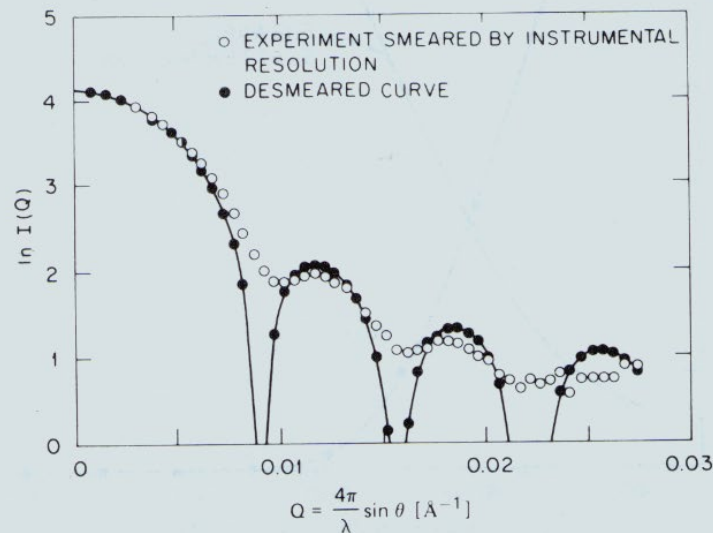

Fig. 4. Plot of $\ln I(Q)$ vs Q for 3.98 vol.% monodisperse PMMA-H spheres (core C1) in D_2O/H_2O mixtures.

Correlations Can Be Measured in Concentrated Systems

- A series of experiments in the late 1980's by Hayter et al and Chen et al produced accurate measurements of $S(Q)$ for colloidal and micellar systems
- To a large extent these data could be fit by $S(Q)$ calculated from the mean spherical model using a Yukawa potential to yield surface charge and screening length

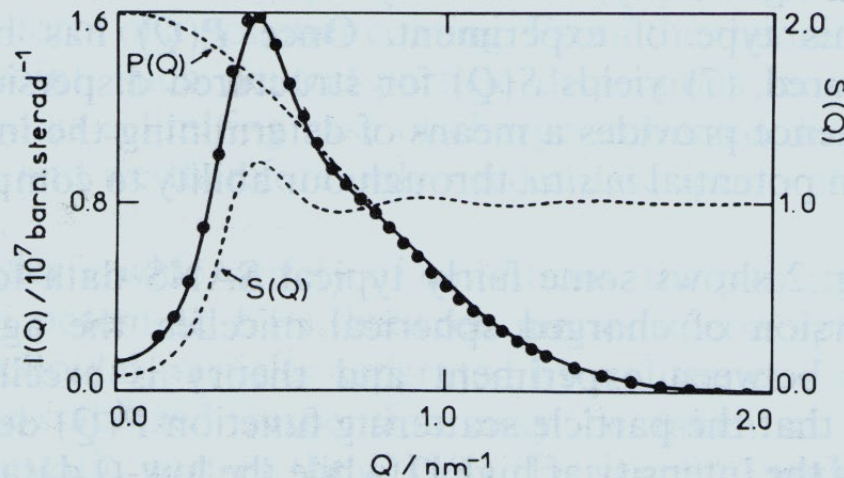
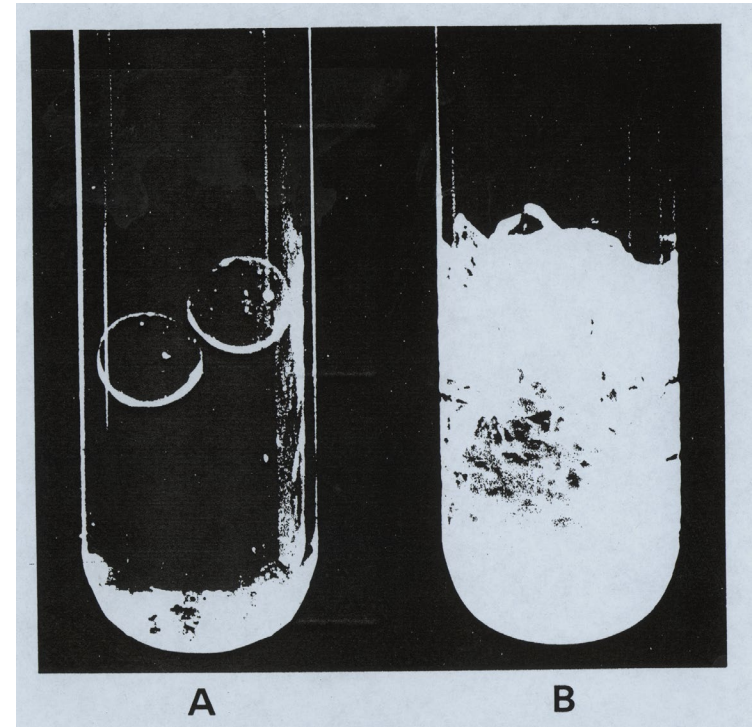
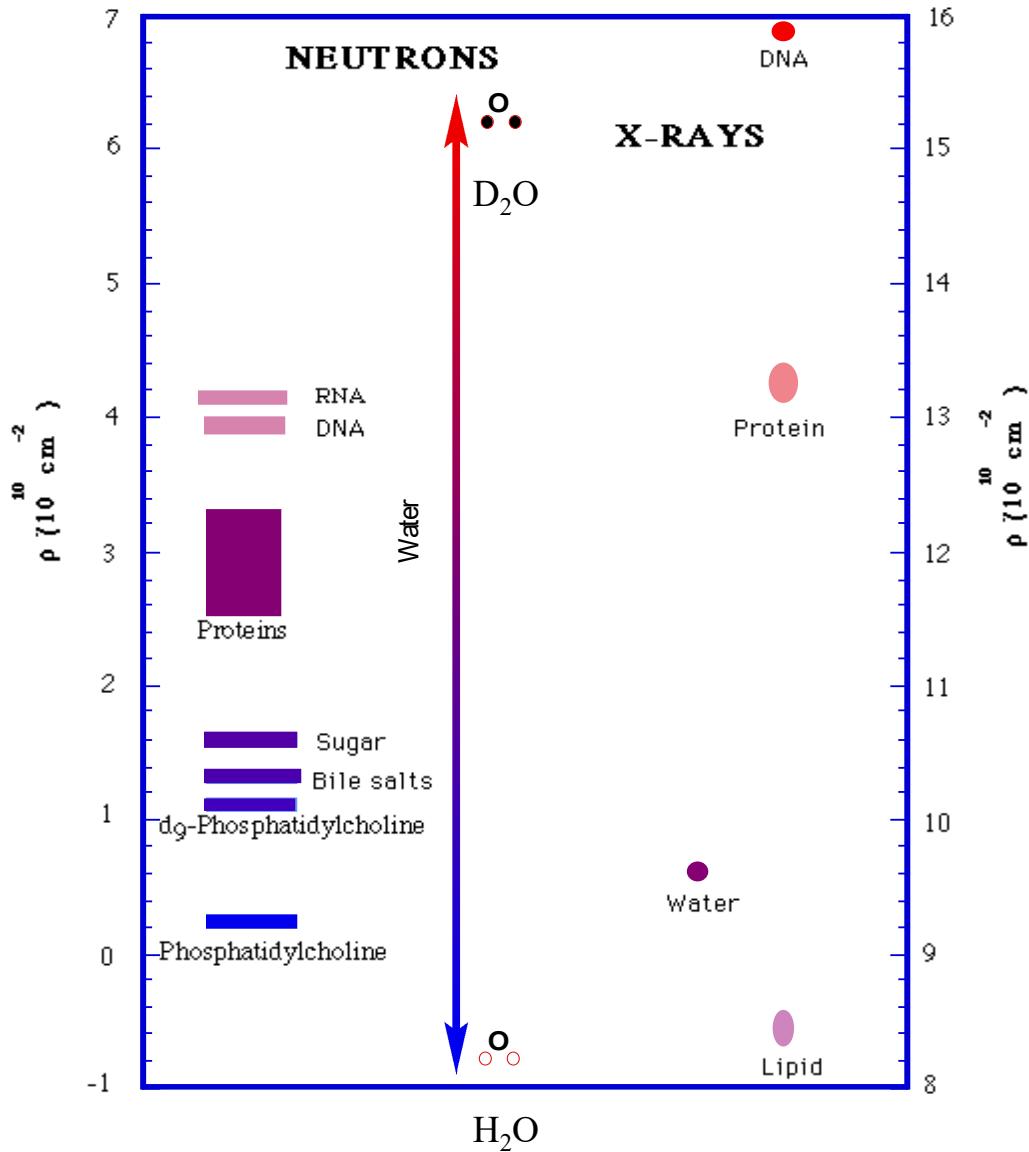

Fig. 2. Observed (●) and calculated (—) scattered intensity $I(Q)$ as a function of momentum transfer Q for a charged micellar dispersion: 0.03 mol dm^{-3} hexadecyltrimethylammonium chloride in D_2O at 313 K. The functions $P(Q)$ and $S(Q)$ are discussed in the text. ($1 \text{ barn sterad}^{-1} = 10^{-28} \text{ M}^2 \text{ sterad}^{-1}$).

Contrast & Contrast Matching



Both tubes contain borosilicate beads + pyrex fibers + solvent. (A) solvent refractive index matched to pyrex; (B) solvent index different from both beads and fibers – scattering from fibers dominates

* Chart courtesy of Rex Hjelm

Contrast Variation

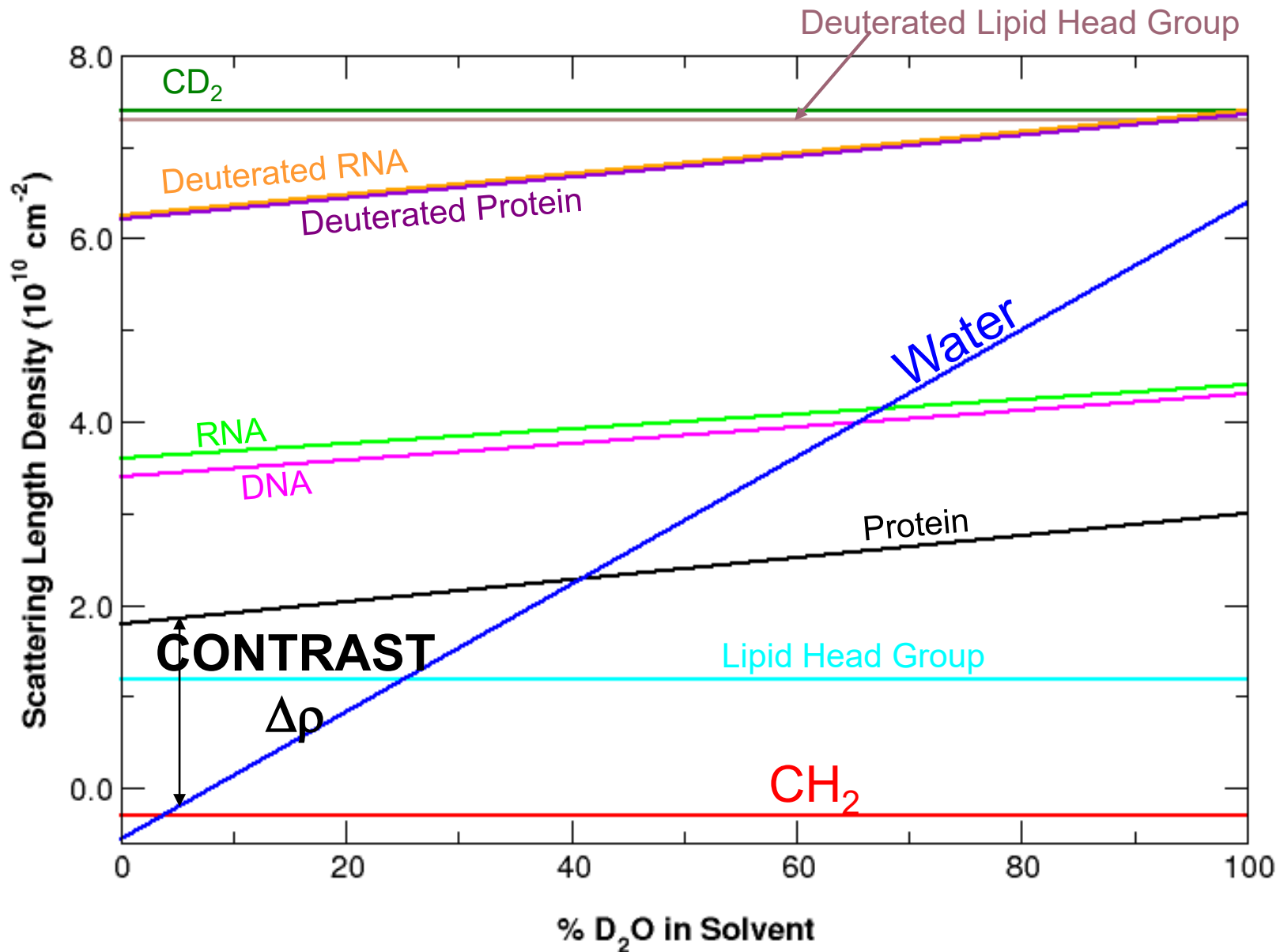

Isotopic Contrast for Neutrons

Hydrogen Isotope	Scattering Length b (fm)
^1H	-3.7409 (11)
^2D	6.674 (6)
^3T	4.792 (27)

Nickel Isotope	Scattering Lengths b (fm)
^{58}Ni	15.0 (5)
^{60}Ni	2.8 (1)
^{61}Ni	7.60 (6)
^{62}Ni	-8.7 (2)
^{64}Ni	-0.38 (7)

Using Contrast Variation to Study Compound Particles

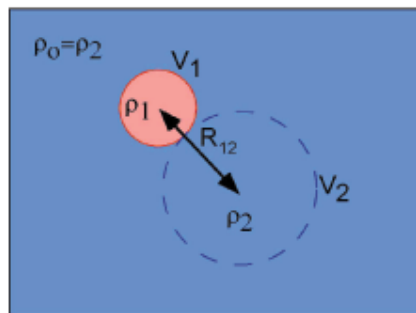

$$I_1(Q) = (\rho_1 - \rho_2)^2 F_1^2$$

Examples include nucleosomes (protein/DNA) and ribosomes (proteins/RNA)

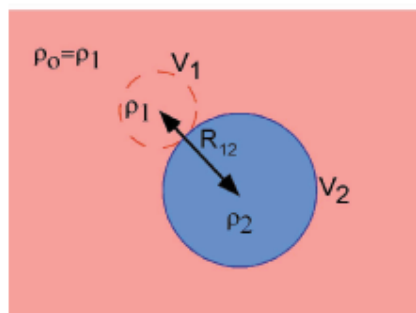

$$I_2(Q) = (\rho_2 - \rho_1)^2 F_2^2$$

$$I(Q) = \frac{N}{V} \left\langle \left| \Delta\rho_1 \int_{V_1} e^{i\vec{Q}\cdot\vec{r}} d\vec{r}_1 + \Delta\rho_2 \int_{V_2} e^{i\vec{Q}\cdot\vec{r}} d\vec{r}_2 \right|^2 \right\rangle$$

$$I(Q) = \Delta\rho_1^2 \langle |F_1(Q)|^2 \rangle + \Delta\rho_2^2 \langle |F_2(Q)|^2 \rangle + \Delta\rho_1 \Delta\rho_2 |F_1(Q)| |F_2(Q)| \frac{\sin(QR_{12})}{QR_{12}}$$

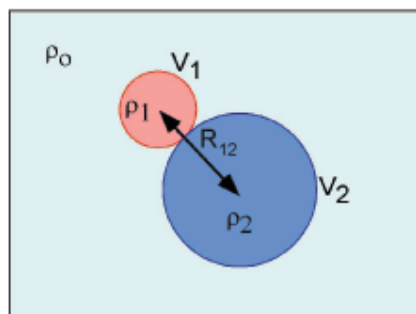

$$I_3(Q) = \frac{(\rho_1 - \rho_0)^2}{(\rho_1 - \rho_2)^2} I_1(Q) - \frac{(\rho_2 - \rho_0)^2}{(\rho_1 - \rho_2)^2} I_2(Q)$$

$$= 2(\rho_1 - \rho_0)(\rho_2 - \rho_0) F_1 F_2 \frac{\sin(QR_{12})}{QR_{12}}$$

$$= 0 \text{ at } Q = \pi/R_{12}$$

Porod Scattering

Let us examine the behavior of $|F(Q)|^2 (QR)^4$ at large values of Q for a spherical particle (i.e. $Q \gg 1/R$ where R is the sphere radius)

$$\begin{aligned} |F(Q)|^2 (QR)^4 &= 9V^2 \left[\frac{\sin QR - QR \cdot \cos QR}{(QR)^3} \right]^2 (QR)^4 = 9V^2 \left[\frac{\sin QR}{QR} - \cos QR \right]^2 \\ &\rightarrow 9V^2 \cos^2 QR \text{ as } Q \rightarrow \infty \\ &= 9V^2 / 2 \text{ on average (the oscillations will be smeared out by resolution)} \end{aligned}$$





Thus $|F(Q)|^2 \rightarrow \frac{9V^2}{2(QR)^4} = \frac{2\pi A}{Q^4}$ where A is the area of the sphere's surface.

This is Porod's law and holds as $Q \rightarrow \infty$ for any particle shape provided the particle surface is smooth.

Another way to obtain it is to expand $G(r) = 1 - ar + br^2 + \dots$ [with $a = A/(2\pi V)$] at small r and to evaluate the form factor with this (Debye) form for the correlation function.

Scattering From Fractal Systems

- Fractals are systems that are “self-similar” under a change of scale I.e. $R \rightarrow CR$
- For a mass fractal the number of particles within a sphere of radius R is proportional to R^D where D is the fractal dimension
- Growth in 2D leads to a variety of values of D ➔

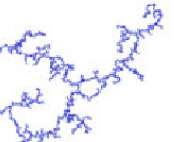
	Reaction-limited	Ballistic	Diffusion-limited
Particle-cluster	 $D_f = 3.00$	 $D_f = 3.00$	 $D_f = 2.50$
Cluster-cluster	 $D_f = 2.09$	 $D_f = 1.95$	 $D_f = 1.80$

Thus

$$4\pi R^2 dR.G(R) = \text{number of particles between distance } R \text{ and } R + dR = cR^{D-1} dR$$

$$\therefore G(R) = (c/4\pi)R^{D-3}$$

$$\text{and } S(\vec{Q}) = \int d\vec{R}.e^{i\vec{Q} \cdot \vec{R}} G(R) = \frac{2\pi}{Q} \int dR.R.\sin QR.(c/4\pi)R^{D-3}$$

$$= \frac{c}{2} \frac{1}{Q^D} \int dx.x^{D-2}.\sin x = \frac{\text{const}}{Q^D}$$

For a surface fractal, one can prove that $S(Q) \propto \frac{\text{const}}{Q^{6-D_s}}$ which reduces to the Porod

form for smooth surfaces of dimension 2.

Typical Intensity Plot for SANS From Disordered Systems

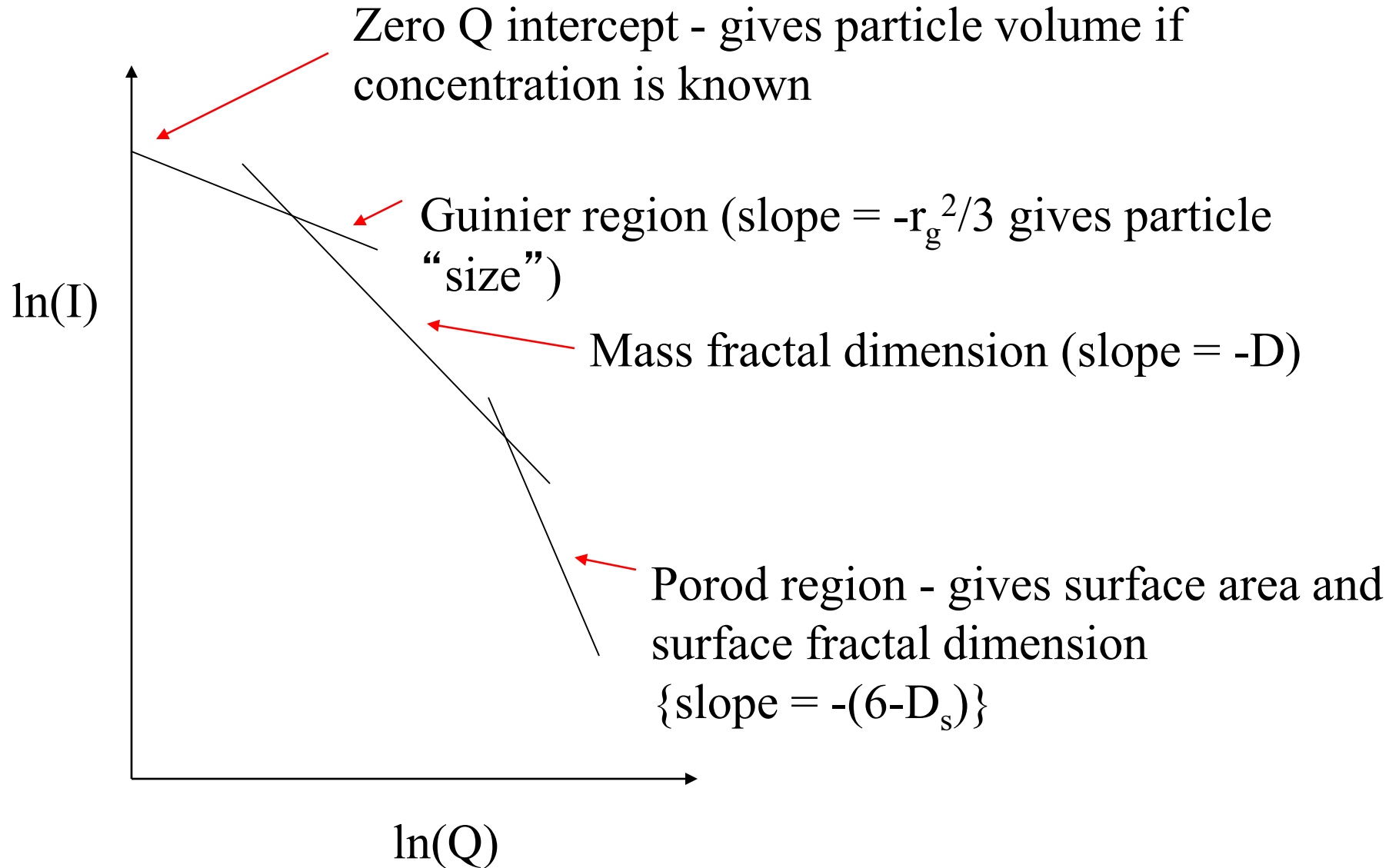

Surface Reflection Is Very Different From Most Neutron and X-ray Scattering

- We worked out the cross section by adding scattering from different scattering centers
 - We ignored double scattering processes because these are usually very weak
- This approximation is called the Born Approximation
- Below an angle of incidence called the critical angle, neutrons and x-rays are perfectly reflected from a smooth surface
 - This is NOT weak scattering and the Born Approximation is not applicable to this case
- Specular reflection is used:
 - In neutron guides and x-ray mirrors
 - In multilayer monochromators and neutron polarizers
 - To probe surface and interface structure in layered systems

Various forms of small (glancing) angle neutron reflection

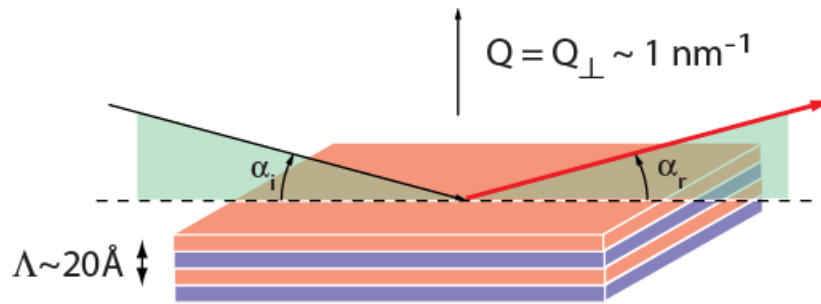

Specular reflectometry

Depth profiles
(nuclear and/or magnetic)

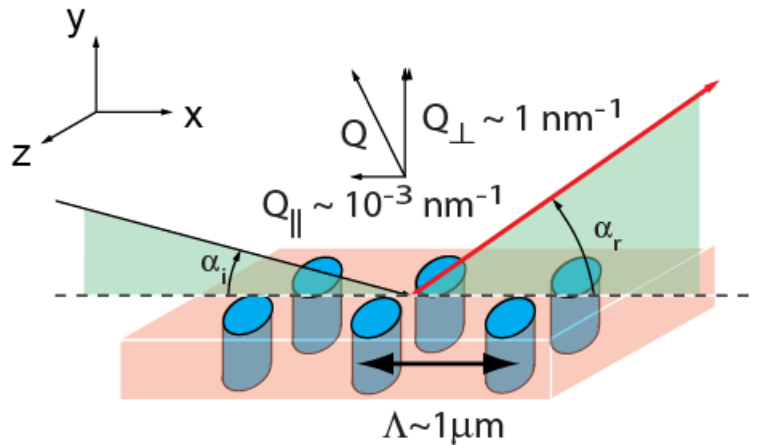

Off-specular (diffuse) scattering

In-plane correlated roughness
Magnetic stripes
Phase separation (polymers)

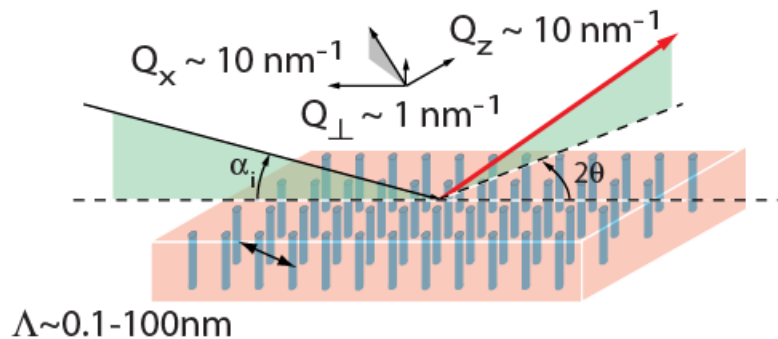

Glancing incidence diffraction

Ordering in liquid crystals
Atomic structures near surfaces
Interactions among nanodots

Only Neutrons With Very Low Velocities Perpendicular to a Surface Are Reflected

$$k / k_0 = n$$

The surface cannot change the neutron velocity parallel to the surface so :

$$k_0 \cos \alpha = k \cos \alpha' = k_0 n \cos \alpha' \quad \text{i.e.} \quad n = \cos \alpha / \cos \alpha'$$

Neutrons obey Snell's Law

$$\text{Since } k^2 = k_0^2 - 4\pi\rho \quad k^2 (\cos^2 \alpha' + \sin^2 \alpha') = k_0^2 (\cos^2 \alpha + \sin^2 \alpha) - 4\pi\rho$$

$$\text{i.e. } k^2 \sin^2 \alpha' = k_0^2 \sin^2 \alpha - 4\pi\rho \quad \text{or } k_z^2 = k_{0z}^2 - 4\pi\rho$$

The critical value of k_{0z} for total external reflection is $k_{0z} = \sqrt{4\pi\rho}$

$$\text{For quartz } k_{0z}^{\text{critical}} = 2.05 \times 10^{-3} \text{ \AA}^{-1}$$

$$(2\pi / \lambda) \sin \alpha_{\text{critical}} = k_{0z}^{\text{critical}} \Rightarrow$$

$$\alpha_{\text{critical}} (^{\circ}) \approx 0.02 \lambda (\text{\AA}) \text{ for quartz}$$

$$\text{Note: } \alpha_{\text{critical}} (^{\circ}) \approx 0.1 \lambda (\text{\AA}) \text{ for nickel}$$

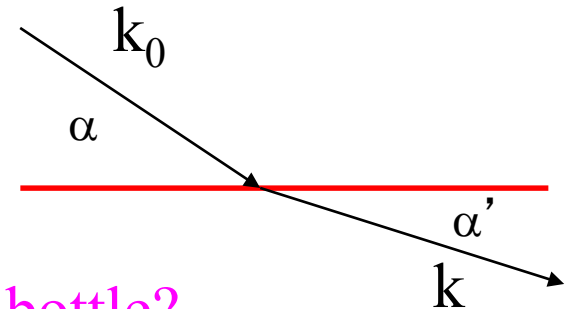

How do we make a neutron bottle?

Refractive Index: X-Rays & Neutrons

$$n_{\text{X}}^2(\vec{r}) = 1 + N \frac{e^2}{m \epsilon_0} \frac{f(\vec{r}, E)}{\omega_0^2 - \omega^2 - 2i \eta_0 \omega} + \text{magnetic part}$$

$$n_{\text{n}}^2(\vec{r}) = 1 - \frac{2m \lambda^2}{h^2} V(\vec{r}) + \text{magnetic part}$$



$$n(\vec{r}) = 1 - \delta(\vec{r}) + i \beta(\vec{r})$$

Minus!!

Dispersion

Absorption

Reflection of Neutrons by a Smooth Surface: Fresnel's Law

continuity

of ψ & $\dot{\psi}$ at $z = 0 \Rightarrow$

$$a_I + a_R = a_T \quad (1)$$

$$a_I \vec{k}_I + a_R \vec{k}_R = a_T \vec{k}_T$$

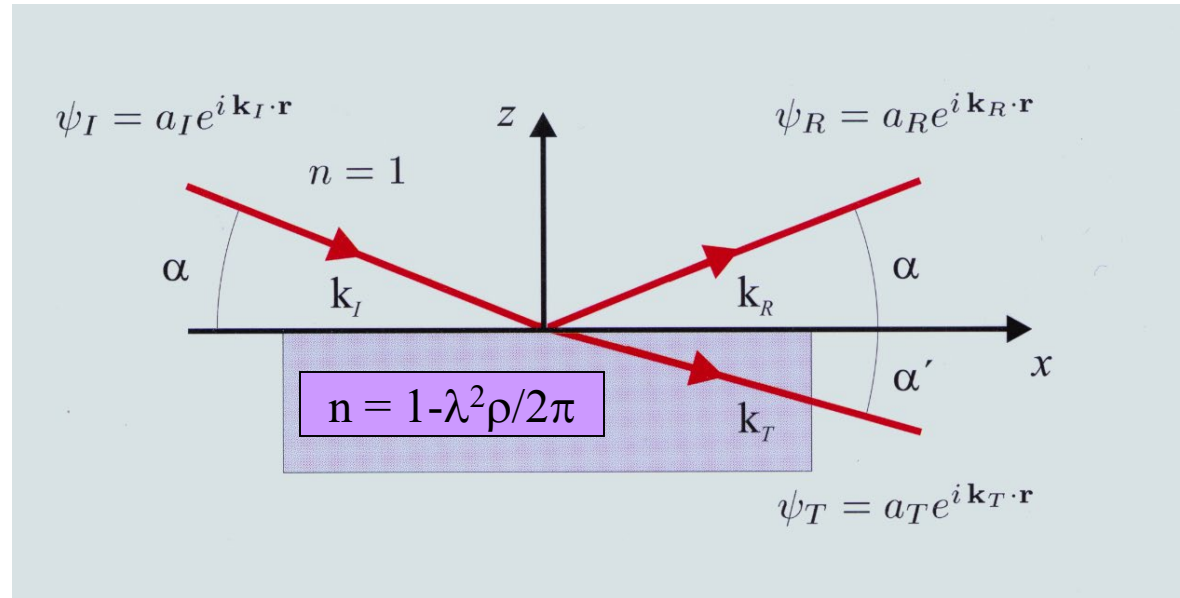

components perpendicular and parallel to the surface :

$$a_I k \cos \alpha + a_R k \cos \alpha = a_T n k \cos \alpha' \quad (2)$$

$$-(a_I - a_R) k \sin \alpha = -a_T n k \sin \alpha' \quad (3)$$

(1) & (2) \Rightarrow Snell's Law : $\cos \alpha = n \cos \alpha'$

$$(1) \text{ \& } (3) \Rightarrow \frac{(a_I - a_R)}{(a_I + a_R)} = n \frac{\sin \alpha'}{\sin \alpha} \approx \frac{\sin \alpha'}{\sin \alpha} = \frac{k_{Tz}}{k_{Iz}}$$

so reflectance is given by $r = a_R / a_I = (k_{Iz} - k_{Tz}) / (k_{Iz} + k_{Tz})$

What do the Amplitudes a_R and a_T Look Like?

- For reflection from a flat substrate, both a_R and a_T are complex when $k_0 < 4\lambda_D$ i.e. below the critical edge. For $a_i = 1$, we find:

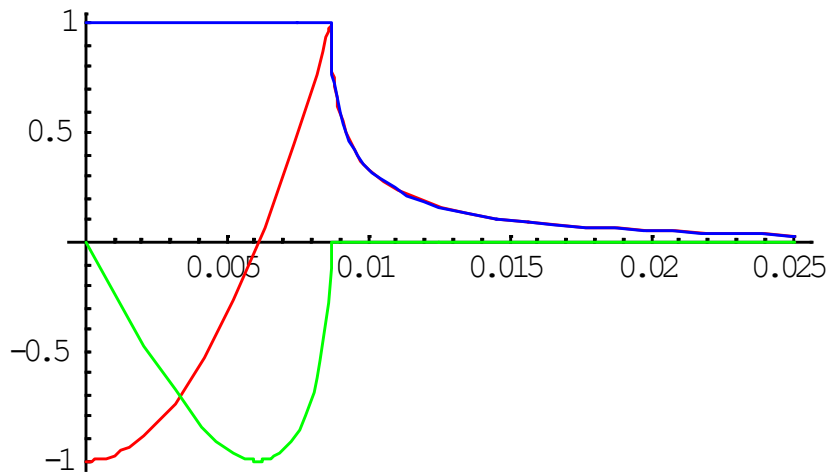

Real (red) & imaginary (green) parts of a_R plotted against k_0 . The modulus of a_R is plotted in blue. The critical edge is at $k_0 \sim 0.009 \text{ A}^{-1}$. Note that the reflected wave is completely out of phase with the incident wave at $k_0 = 0$

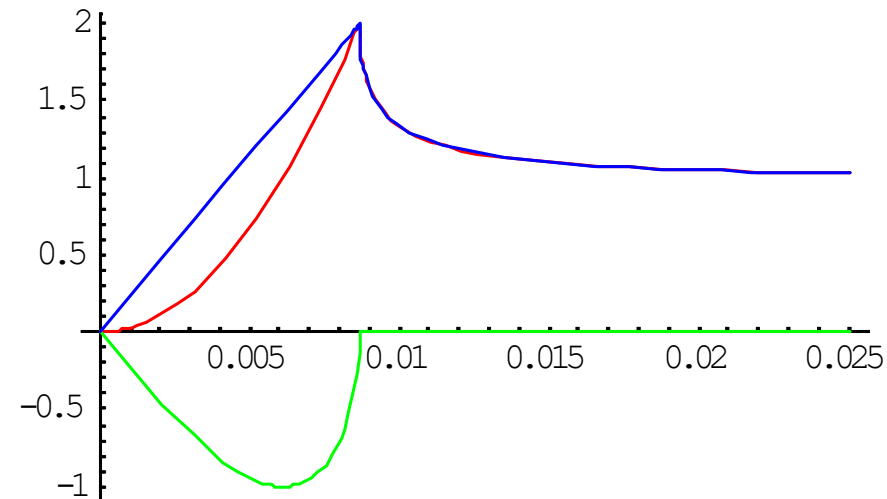

Real (red) and imaginary (green) parts of a_T . The modulus of a_T is plotted in blue. Note that a_T tends to unity at large values of k_0 as one would expect and that the transmitted intensity peaks at the critical edge.

Penetration Depth

- In the absence of absorption, the penetration depth becomes infinite at large enough angles
- Because k_z is imaginary below the critical edge (recall that $k_z^2 = k_{0z}^2 - 4\pi\rho$), the transmitted wave is evanescent
- The penetration depth $\Lambda = 1/\text{Im}(k)$
- Around the critical edge, one may tune the penetration depth to probe different depths in the sample

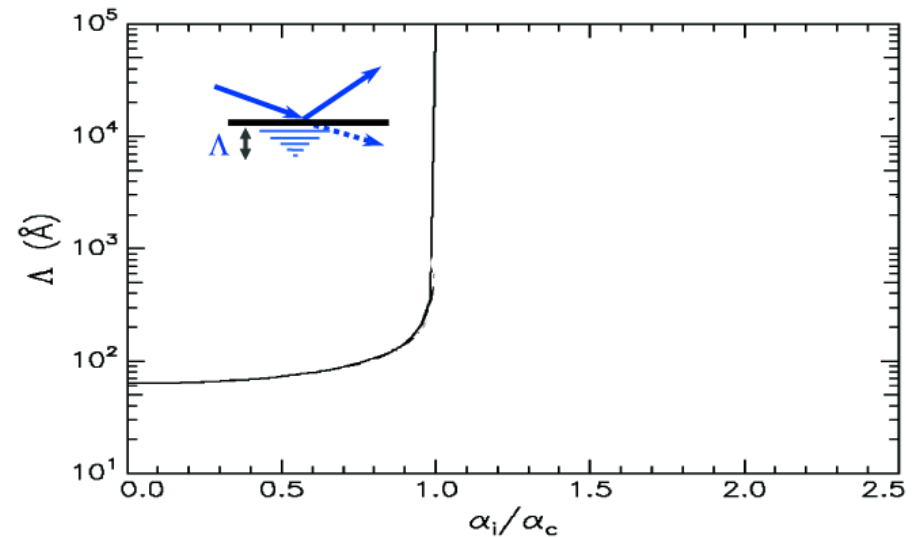

Measured Reflectivity

- We do not measure the reflectance, r , but the reflectivity, R given by:

$$R = \frac{\text{\# of neutrons reflected at } Q_z}{\text{\# of incident neutrons}} = r \cdot r^*$$

i.e., just as in diffraction, we lose phase information

- Notice, also, that the measurement averages the reflectivity over the surface of the sample:
i.e. measured reflectivity depends on

$$\bar{\rho}(z) = \frac{1}{S} \int dx \int dy \rho(x, y, z)$$

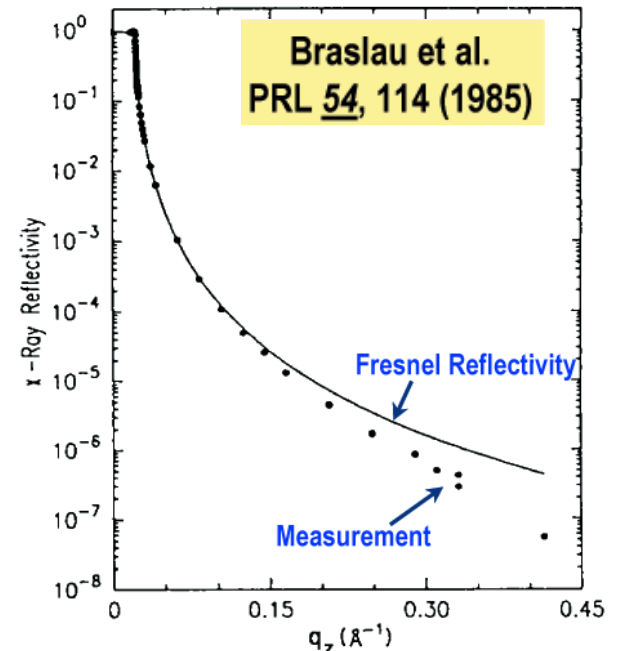

Measured and Fresnel reflectivities for water – difference is due to surface roughness

Fresnel's Law for a Thin Film

- $r = (k_{0z} - k_{1z}) / (k_{1z} + k_{0z})$ is Fresnel's law
- Evaluate with $\rho = 4 \cdot 10^{-6} \text{ \AA}^{-2}$ gives the red curve with critical wavevector given by $k_{0z} = (4\rho)^{1/2}$
- If we add a thin layer on top of the substrate we get interference fringes & the reflectance is given by:

$$r = \frac{r_{01} + r_{12} e^{i2k_{1z}t}}{1 + r_{01}r_{12} e^{i2k_{1z}t}}$$

and we measure the reflectivity $R = r \cdot r^*$

- If the film has a higher scattering length density than the substrate we get the green curve (if the film scattering is weaker than the substance, the green curve is below the red one)
- The fringe spacing at large k_{0z} is $\sim \lambda/t$ (a 250 Å film was used for the figure)

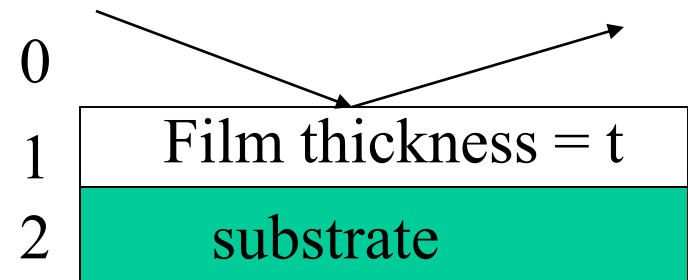
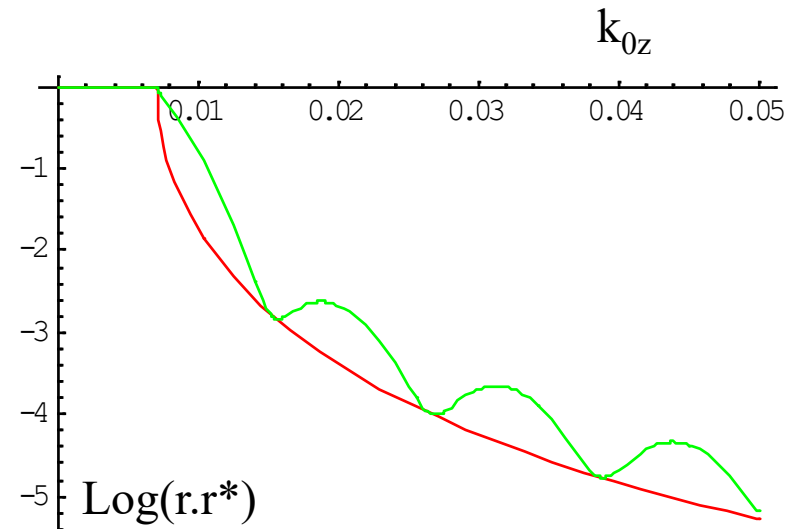

Multiple Layers – Parratt Iteration (1954)

- The same method of matching wavefunctions and derivatives at interfaces can be used to obtain an expression for the reflectivity of multiple layers

$$X_j = \frac{R_j}{T_j} = e^{-2ik_{z,j}z_j} \frac{r_{j,j+1} + X_{j+1}e^{2ik_{z,j+1}z_j}}{1 + r_{j,j+1}X_{j+1}e^{2ik_{z,j+1}z_j}}$$

where $r_{j,j+1} = \frac{k_{z,j} - k_{z,j+1}}{k_{z,j} + k_{z,j+1}}$

Start iteration with

$$R_{N+1} = X_{N+1} = 0 \text{ and } T_1 = 1$$

(i.e. nothing coming back from inside substrate & unit amplitude incident wave)

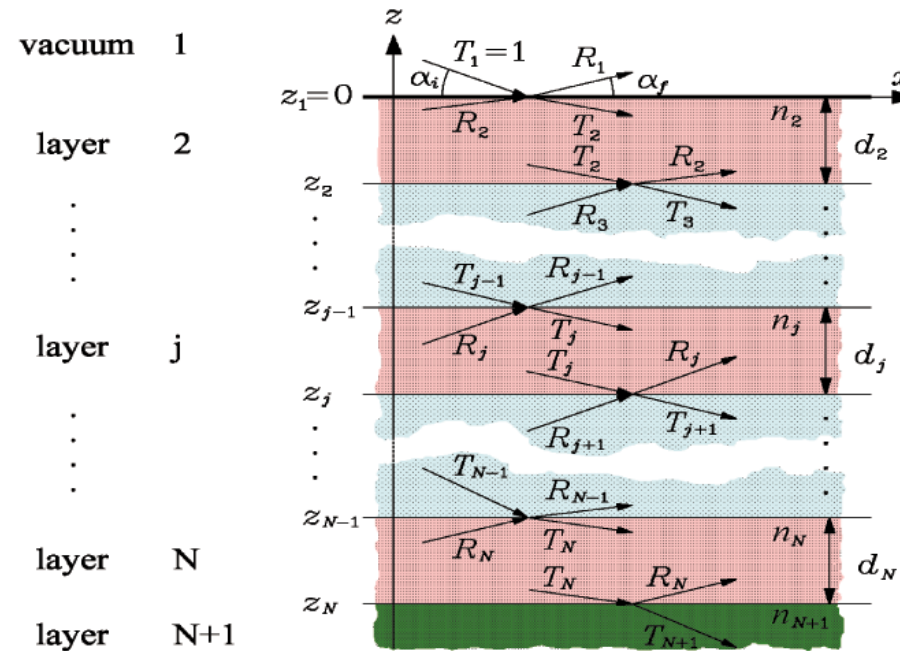
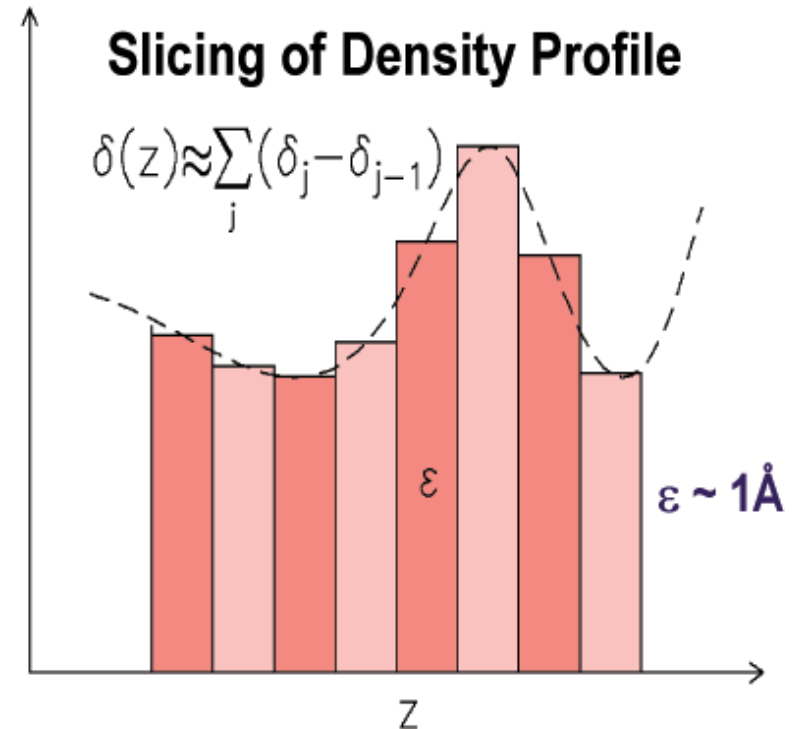

Image from M. Tolan

Dealing with Varying Density Profiles

- Any SLD depth profile can be “chopped” into slices
- The Parratt formalism allows the reflectivity to be calculated
- A thickness resolution of 1 Å is adequate – this corresponds to a value of Q_z where the reflectivity has dropped below what neutrons can normally measure
- Computationally intensive!!



When Does a “Rough” Surface Scatter Diffusely?

- Rayleigh criterion

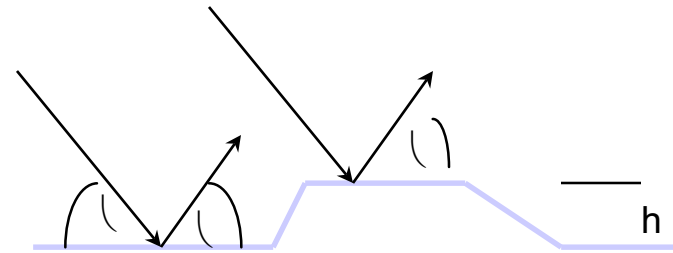

path difference: $\Delta r = 2 h \sin \theta$

phase difference: $\Delta \Phi = (4\pi h / \lambda) \sin \theta$

boundary between rough and smooth: $\Delta \Phi = \pi / 2$

that is $h < \lambda / (8 \sin \theta)$ for a smooth surface

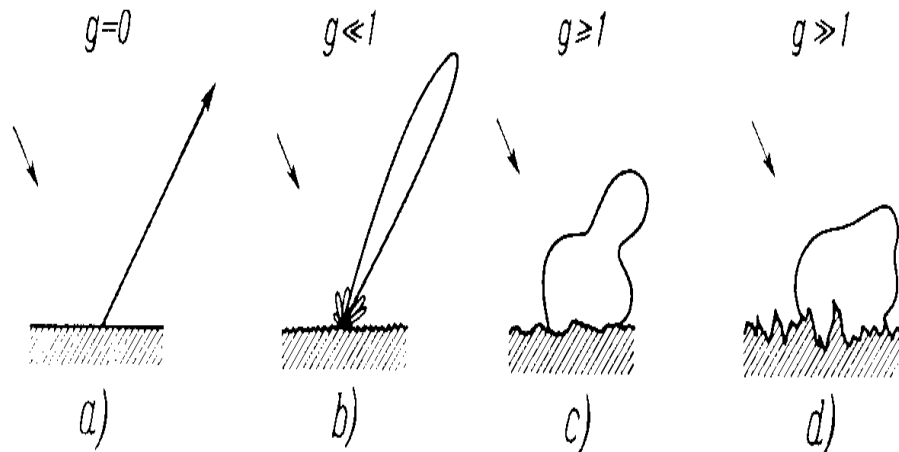

where $g = 4\pi h \sin \theta / \lambda = Q_z h$

Surface Roughness

- Surface roughness causes diffuse (non-specular) scattering and so reduces the magnitude of the specular reflectivity

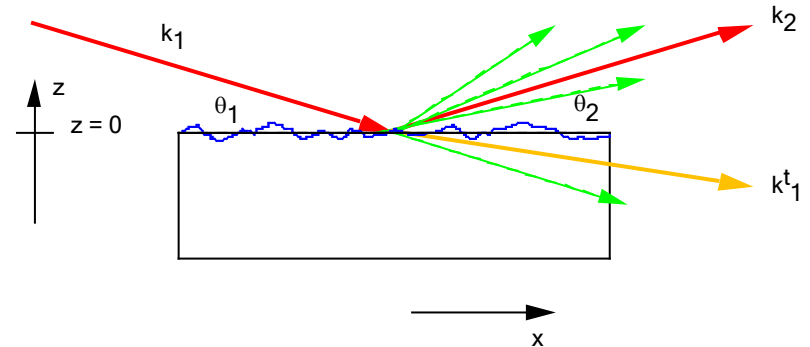

- The way in which the specular reflection is damped depends on the length scale of the roughness in the surface as well as on the magnitude and distribution of roughness

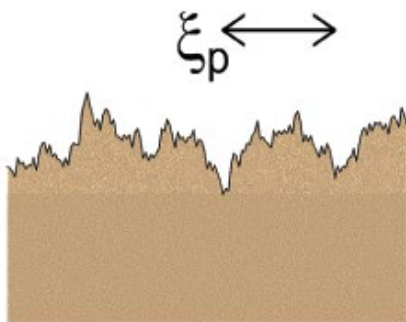

“sparkling sea” model
-- specular from many facets

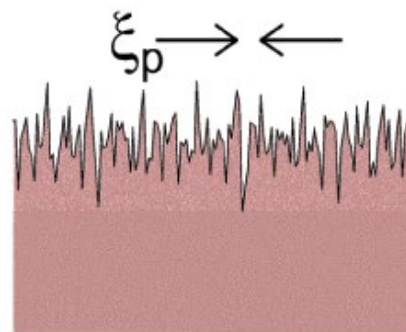

each piece of surface scatters independently
-- Nevot Croce model

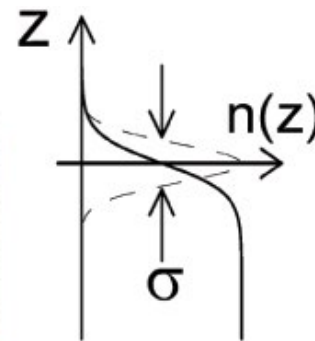

Note that roughness introduces a SLD profile averaged over the sample surface

$$\longrightarrow R = R_F e^{-2k_{Iz}k_{1z}^t\sigma^2}$$

Kinematic (Born) Approximation

- We defined the scattering cross section in terms of an incident plane wave & a **weakly** scattered spherical wave (called the Born Approximation)
- This picture is not correct for surface reflection, except at large values of Q_z
- For large Q_z , one may use the definition of the scattering cross section to calculate R for a flat surface (in the Born Approximation) as follows:

$$R = \frac{\text{number of neutrons reflected by a sample of size } L_x L_y}{\text{number of neutrons incident on sample } (= \Phi L_x L_y \sin \alpha)}$$
$$= \frac{\sigma}{L_x L_y \sin \alpha} = \frac{1}{L_x L_y \sin \alpha} \int \frac{d\sigma}{d\Omega} d\Omega = \frac{1}{L_x L_y \sin \alpha} \int \frac{d\sigma}{d\Omega} \frac{dk_x dk_y}{k_0^2 \sin \alpha}$$

because $k_x = k_0 \cos \alpha$ so $dk_x = -k_0 \sin \alpha d\alpha$.

From the definition of a cross section we get for a smooth substrate :

$$\frac{d\sigma}{d\Omega} = \rho^2 \int d\vec{r} \int d\vec{r}' e^{i\vec{Q} \cdot (\vec{r} - \vec{r}')} = \rho^2 \frac{4\pi^2}{Q_z^2} L_x L_y \delta(Q_x) \delta(Q_y) \text{ so } R = 16\pi^2 \rho^2 / Q_z^4$$

It is easy to show that this is the same as the Fresnel form at large Q_z

Reflection by a Graded Interface

Repeating the bottom line of the previous viewgraph but keeping the z - dependence

of ρ gives :
$$R = \frac{16\pi^2}{Q_z^2} \left| \int \rho(z) e^{iQ_z z} dz \right|^2 = \frac{16\pi^2}{Q_z^4} \left| \int \frac{d\rho(z)}{dz} e^{iQ_z z} dz \right|^2$$
 where the second

equality follows after intergrating by parts.

If we replace the prefactor by the Fresnel reflectivity R_F , we get the right answer for a smooth interface, as well as the correct form at large Q_z

$$R = R_F \left| \int \frac{d\rho(z)}{dz} e^{iQ_z z} dz \right|^2$$

This can be solved analytically for several convenient forms of $d\rho/dz$ such as $1/\cosh^2(z)$. This approximate equation illustrates an important point : reflectivity data cannot be inverted uniquely to obtain $\rho(z)$, because we generally lack important phase information. This means that models refined to fit reflectivity data must have good physical justification.

Refractive Index: X-Rays

$$n(z) = 1 - \frac{\lambda^2}{2\pi} r_e \rho(z) + i \frac{\lambda}{4\pi} \mu(z)$$

	$r_e \rho (10^{10} \text{cm}^{-2})$	$\delta (10^{-6})$	$\mu (\text{cm}^{-1})$	$\alpha_c (^\circ)$
Vacuum	0	0	0	0
PS (C_8H_8) _n	9.5	3.5	4	0.153
PMMA ($\text{C}_5\text{H}_8\text{O}_2$) _n	10.6	4.0	7	0.162
PVC ($\text{C}_2\text{H}_3\text{Cl}$) _n	12.1	4.6	86	0.174
PBrS ($\text{C}_8\text{H}_7\text{Br}$) _n	13.2	5.0	97	0.181
Quartz (SiO_2)	18.0–19.7	6.8–7.4	85	0.21–0.22
Silicon (Si)	20.0	7.6	141	0.223
Nickel (Ni)	72.6	27.4	407	0.424
Gold (Au)	131.5	49.6	4170	0.570

$$\rho(z) = \langle \rho(x, y, z) \rangle_{x,y}$$

**Electron Density
Profile !**

E = 8 keV λ = 1.54 Å

Comparison of Neutron and X-Ray Reflectivity

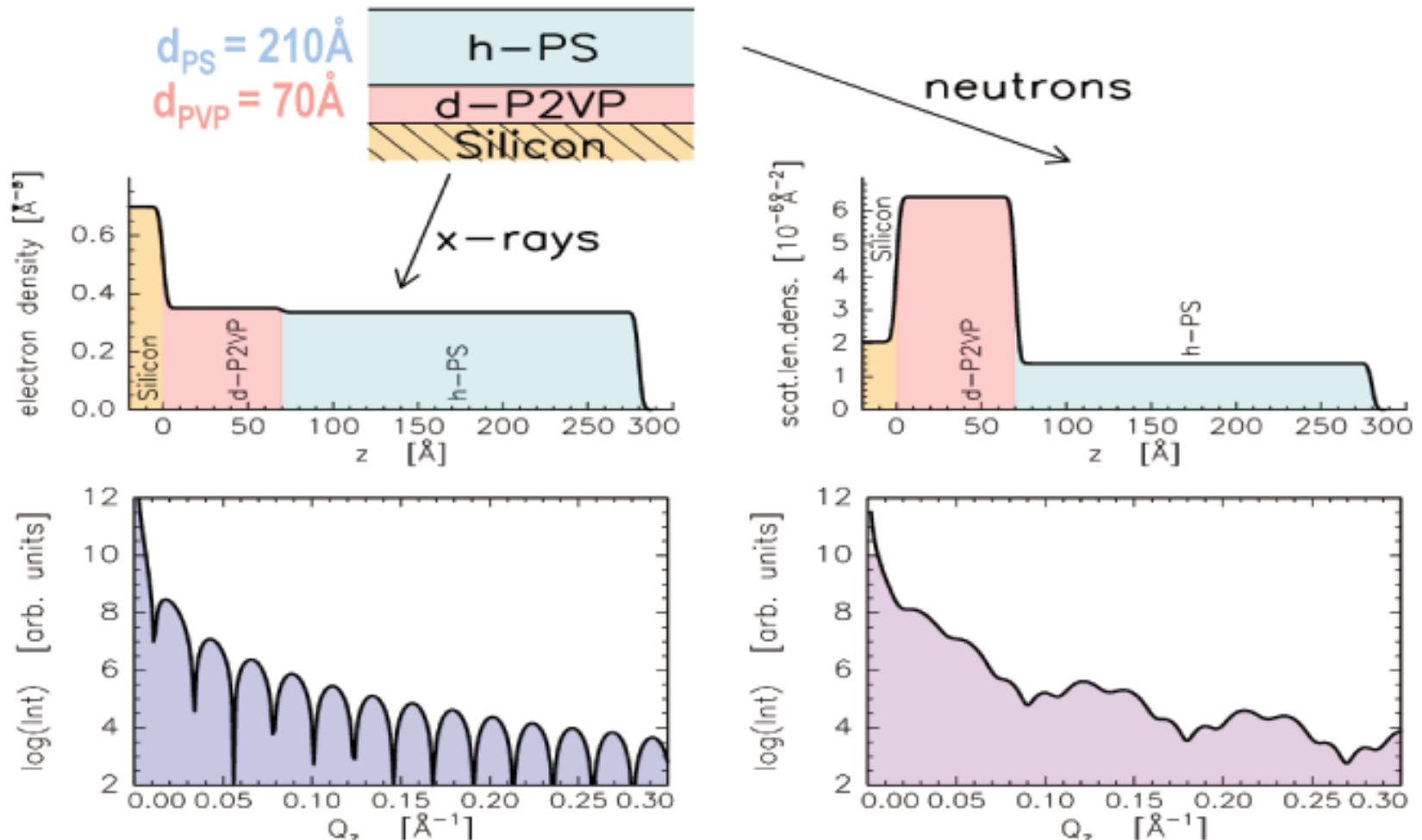

Neutrons often provide better contrast and don't damage samples
X-rays provide better Q resolution and higher Q values

The Goal of Reflectivity Measurements Is to Infer a Density Profile Perpendicular to a Flat Interface

- In general the results are not unique, but independent knowledge of the system often makes them very reliable
 - It is possible to get unique results by using different "backings"
- Frequently, layer models are used to fit the data
- Advantages of neutrons include:
 - Contrast variation (using H and D, for example)
 - Low absorption – probe buried interfaces, solid/liquid interfaces etc
 - Non-destructive
 - Sensitive to magnetism
 - Thickness length scale 10 – 5000 Å
- Issues include
 - Generally no unique solution for the SLD profile (use prior knowledge)
 - Large samples ($> 1 \text{ cm}^2$) with good scattering contrast are needed for neutrons

What do Specular and Off-specular scattering measure?

- **Specular reflectivity** measures variations in scattering density normal to surface (averaged over x,y plane)
- **Off-specular scattering** measures (x,y) variations of scattering density, e.g. due to roughness, magnetic domains, etc.

Vector Diagram for Q in GISAXS

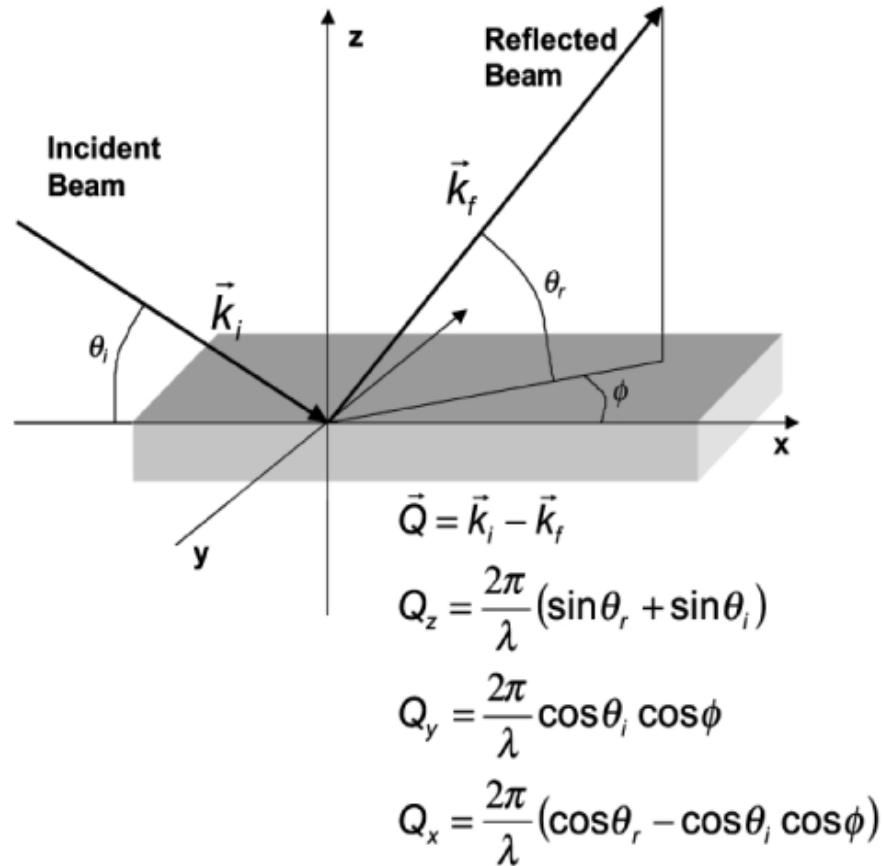

Note that the length scales measured parallel to the surface when both k_i and k_f are in the specular plane are much greater than the length scale measured perpendicular to the surface

X-Ray Reflectometers

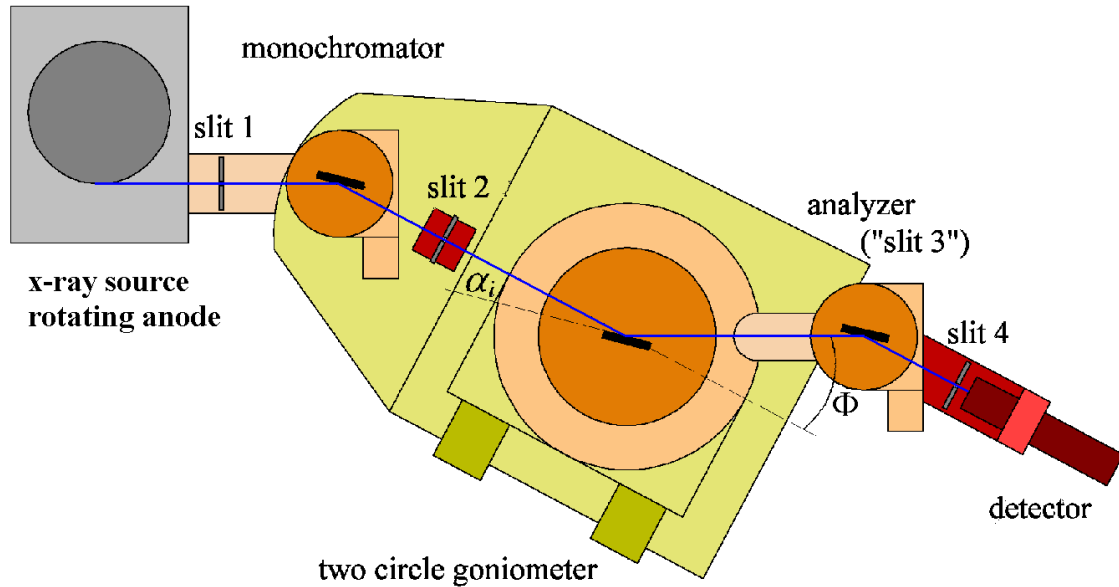

Laboratory Setup

Synchrotron Setup

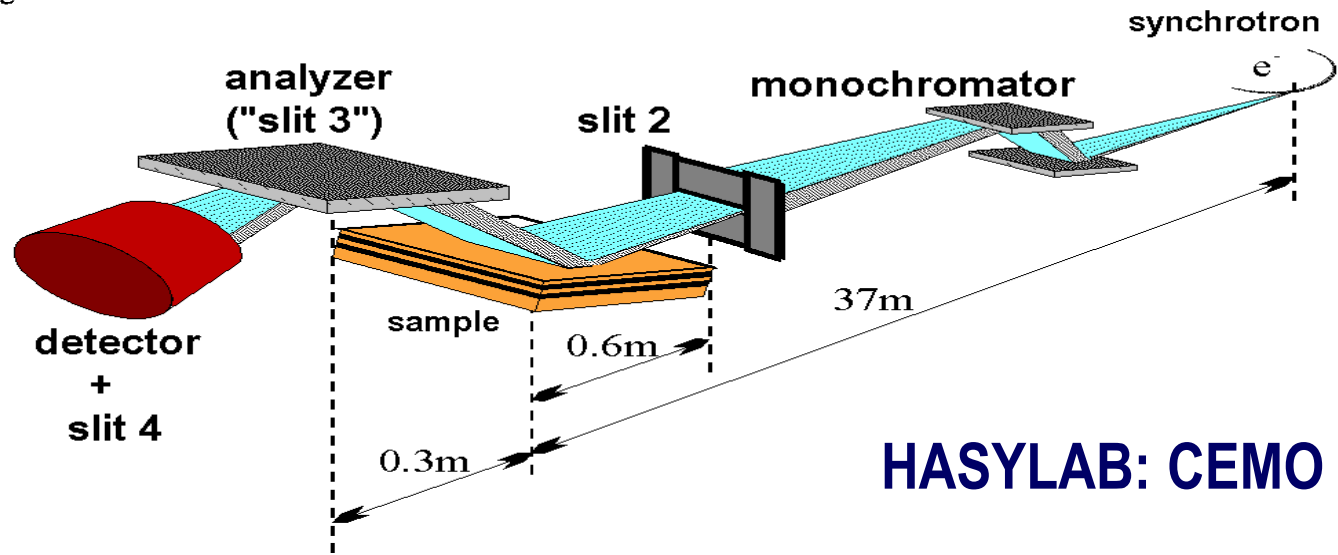

HASYLAB: CEMO

Reflectivity from Liquids I

Synchrotron
Setup (APS)

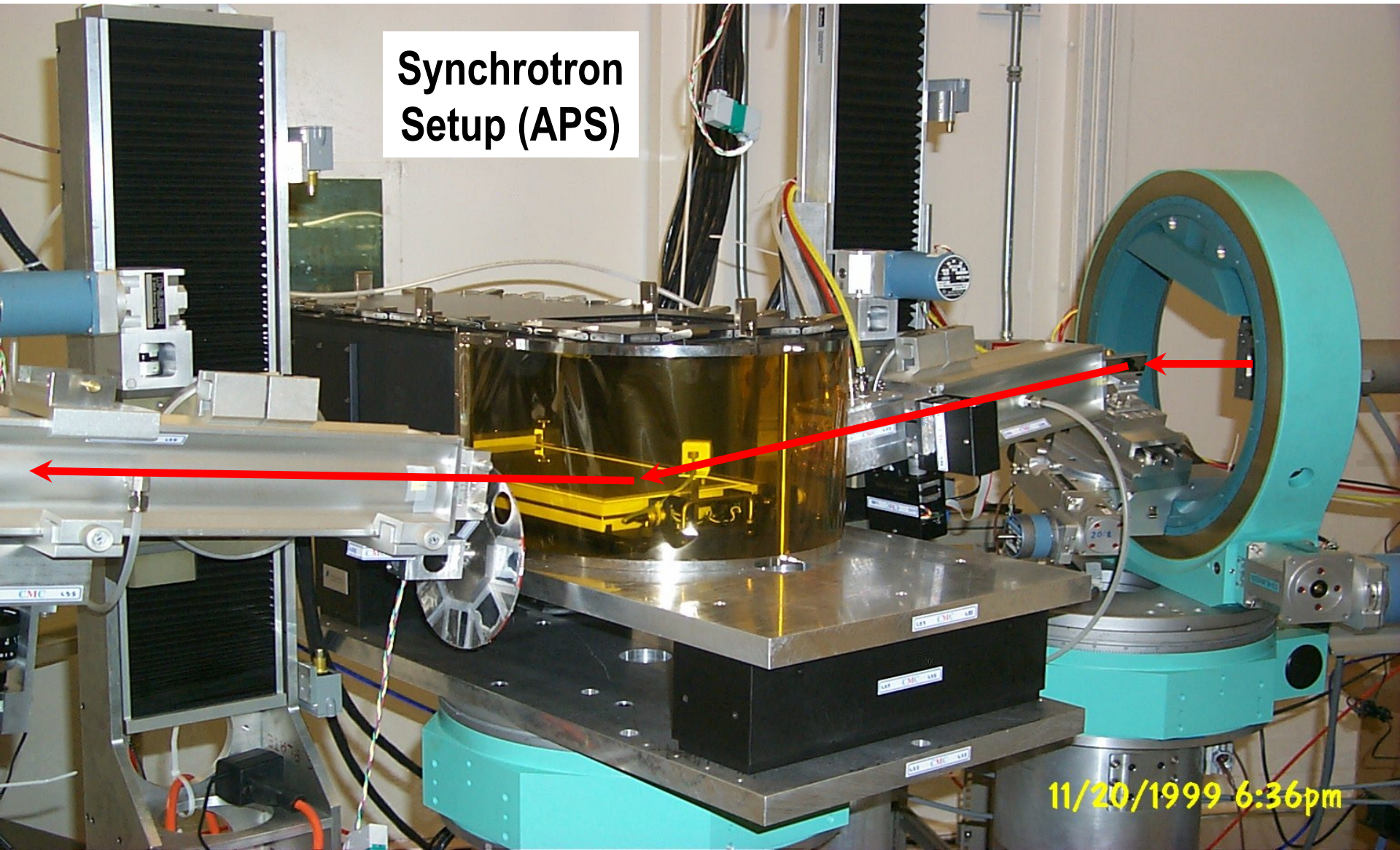

11/20/1999 6:36pm

END