



## Thermo Scientific Lindberg/Blue M Moldatherm 1100°C Box Furnace

Models: BF51728, BF51748, BF51766, BF51794  
BF51828, BF51848, BF51866, BF51894

### Installation and Operational Manual

330985H01 Rev. C October, 2020

© 2020 Thermo Fisher Scientific Inc. All rights reserved.

Thermo Fisher Scientific Inc. provides this document to its customers with a product purchase to use in the product operation. This document is copyright protected and any reproduction of the whole or any part of this document is strictly prohibited, except with the written authorization of Thermo Fisher Scientific Inc.

The contents of this document are subject to change without notice. All technical information in this document is for reference purposes only. System configurations and specifications in this document supersede all previous information received by the purchaser.

Thermo Fisher Scientific Inc. makes no representations that this document is complete, accurate or error-free and assumes no responsibility and will not be liable for any errors, omissions, damage or loss that might result from any use of this document, even if the information in the document is followed properly.

This document is not part of any sales contract between Thermo Fisher Scientific Inc. and a purchaser. This document shall in no way govern or modify any Terms and Conditions of Sale, which Terms and Conditions of Sale shall govern all conflicting information between the two documents.

# Table of Contents

<b>Chapter 1</b>	<b>Safety Notes</b> . . . . .	<b>1-5</b>
	Explanation of Symbols . . . . .	1-5
	Safety Considerations . . . . .	1-7
	Standards and Directives . . . . .	1-9
	Electromagnetic Compatibility . . . . .	1-9
<b>Chapter 2</b>	<b>Introduction</b> . . . . .	<b>2-13</b>
	Features and Benefits . . . . .	2-13
	Intended Use . . . . .	2-14
	Non-Intended Use . . . . .	2-14
	Specifications . . . . .	2-15
<b>Chapter 3</b>	<b>Pre-Installation</b> . . . . .	<b>3-17</b>
	Unpacking . . . . .	3-17
	Operating Conditions . . . . .	3-17
	Environmental Conditions . . . . .	3-17
	Atmosphere Systems . . . . .	3-18
<b>Chapter 4</b>	<b>Installation</b> . . . . .	<b>4-19</b>
	Lifting and Carrying . . . . .	4-19
	Transport . . . . .	4-19
	Location . . . . .	4-19
	Wiring . . . . .	4-19
	Wiring for BF51728 / BF51828 models . . . . .	4-20
	Mains Electrical/Thermocouple Check . . . . .	4-21
	Exhaust Vent . . . . .	4-22
	Exhaust Port Connections . . . . .	4-22
	Atmosphere Inlet . . . . .	4-23
	Atmosphere Inlet Port . . . . .	4-23
	Hearth Plate Information . . . . .	4-24
<b>Chapter 5</b>	<b>Start-Up</b> . . . . .	<b>5-25</b>
	Initial Furnace Start-Up/Drying-Out Process . . . . .	5-25
	Door Seal Check . . . . .	5-26
	Door Seal Adjustment (if necessary) . . . . .	5-26
<b>Chapter 6</b>	<b>Main Controller: 1x8 &amp; 5x16 Segment Programmable</b> . . . . .	<b>6-29</b>
	Eurotherm 3216 Controller . . . . .	6-29
	Operator Interface & HOME Display . . . . .	6-30
	Beacon Display and Description . . . . .	6-30
	Operator Buttons . . . . .	6-31
	Single Set Point Operation . . . . .	6-31
	Alternate Set Point Selection (SP2) . . . . .	6-32
	Set Point Ramp Rate . . . . .	6-32
	View or Change the Display Units . . . . .	6-33
	Auto Tuning . . . . .	6-34
	Parameter List . . . . .	6-35
	Offset Procedure . . . . .	6-37
	Alarms & Diagnostics . . . . .	6-38
	Sensor Break & Loop Break Protection . . . . .	6-39
	Over-Temperature Protection (OTP) . . . . .	6-39

	1-Program 8-Segment Controller Operation . . . . .	6-41
	Soft Start Timer . . . . .	6-43
	Delayed Switch On Timer . . . . .	6-44
	5-Program 16-Segment Controller Operation . . . . .	6-49
<b>Chapter 7</b>	<b>Communication Option . . . . .</b>	<b>7-55</b>
	Adapters - RS 485 to RS 232/USB . . . . .	7-55
	Host Computer & Software . . . . .	7-55
	Controller Parameters for Communication . . . . .	7-56
<b>Chapter 8</b>	<b>Maintenance &amp; Cleaning . . . . .</b>	<b>8-57</b>
	Cleaning and Decontamination . . . . .	8-57
	Thermocouple Replacement . . . . .	8-58
	Solid-State Relay Replacement . . . . .	8-59
	Contactors Replacement . . . . .	8-60
	Temperature Controller Replacement . . . . .	8-61
	Door Insulation Replacement . . . . .	8-61
	Heating Unit Replacement . . . . .	8-62
<b>Chapter 9</b>	<b>Troubleshooting . . . . .</b>	<b>9-65</b>
<b>Chapter 10</b>	<b>Wiring Diagram . . . . .</b>	<b>10-67</b>
<b>Chapter 11</b>	<b>Detachable Power Cord Options . . . . .</b>	<b>11-71</b>
<b>Chapter 12</b>	<b>Replacement Parts . . . . .</b>	<b>12-73</b>
<b>Chapter 13</b>	<b>End of Life Care . . . . .</b>	<b>13-81</b>
	WEEE Compliance . . . . .	13-82
<b>Chapter 14</b>	<b>Contact Information . . . . .</b>	<b>14-83</b>

# Figures

Figure 1 1100°C Box Furnace .....	2-13
Figure 2 Thermocouple .....	4-21
Figure 3 Exhaust Vents .....	4-22
Figure 4 Preventing Chimney Effect.....	4-23
Figure 5 Atmosphere Inlet Port .....	4-24
Figure 6 Thermocouple Replacement .....	8-59
Figure 7 Solid Relay Replacement .....	8-60
Figure 8 Door Insulation Replacement .....	8-61
Figure 9 Heating Unit Replacement .....	8-63
Figure 10 Wiring Diagram (BF51748, BF51766, BF51848 & BF51866) .....	10-67
Figure 11 Wiring Diagram (BF51794, BF51894) .....	10-68
Figure 12 Wiring Diagram (BF51728, BF51828) .....	10-69



# Safety Notes

## Explanation of Symbols



This symbol when used alone indicates important operating instructions which reduce the risk of injury or poor performance of the unit.



**DANGER :** Indicates a hazardous situation which, if not avoided, will result in death or serious injuries.



**WARNING :** Indicates a hazardous situation which, if not avoided, could result in death or serious injuries.



**CAUTION :** Indicates a situation which, if not avoided, could result in damage to equipment or property.



Before installing, using or maintaining this product, please be sure to read the manual and product warning labels carefully. Failure to follow these instructions may cause the product to malfunction, which could result in injury or damage



This symbol indicates possible pinch points which may cause personal injury.



This symbol indicates surfaces which may become hot during use and may cause a burn if touched with unprotected body parts.



**WARNING :** This symbol indicates situations where dangerous voltages exist and potential for electrical shock is present.



This symbol indicates a need to use gloves during the indicated procedures. If performing decontamination procedures, use chemically resistant gloves.

Use gloves during the daily usage.



**WARNING :** This symbol indicates a situation which fire hazards exists in the Product.



**WARNING :** Unauthorized repair of your Furnace will invalidate your warranty. Contact Technical Service at 1-800-438-4851 for additional information.



This symbol indicates power is ON.



This symbol indicates power is OFF.



This symbol indicates Alternating current.



This symbol indicates Earth ground power.



This symbol indicates Protective conductor terminal.



## Safety Considerations

**DANGER :**

Do not modify or use equipment in a manner other than expressly intended. Modification of equipment other than that for which it is explicitly designed could cause severe injury or death. Any customer after-market retrofit violates the warranty of the equipment.

Do not modify or disconnect any safety features provided. Disconnection of the unit safety features could allow the unit to become overheated and start on fire, causing personal injury or death, product and property damage.

Do not use components or materials not specifically designed for this equipment. Failure to comply with this precaution could result in damage to equipment used or the furnace and may create an overheat situation. Also, do not use anything other than OEM exact replacement equipment and parts. Not using OEM replacement parts could cause faulty instrumentation readings, inoperable equipment, or temperature overshoot. Both situations may cause personal injury or death, product, and property damage.

Before using, user shall determine the suitability and integrity of the product for the intended use and that the unit has not been altered in any way. Misapplication may compromise the safety of the end user or the life of the product.



**WARNING :** Use appropriate Personal Protective Equipment (PPE) per local protocols.



**CAUTION :** This product contains refractory ceramic fiber or other refractories which can result in the following:

- May be irritating to skin, eyes, and respiratory tract.
- May be harmful if inhaled.
- May contain or form cristobalite (crystalline silica) with use at high temperature (above 871°C (1599.8°F)) which can cause severe respiratory disease.
- Possible cancer hazard based on tests with laboratory animals. Animal studies to date are inconclusive. No human exposure studies with this product have been reported.



**WARNING :** This product can expose you to chemicals including arsenic, which is known to the state of California to cause cancer. For more information go to [www.P65Warnings.ca.gov](http://www.P65Warnings.ca.gov).



**WARNING :** Before maintaining this equipment, read the applicable SDS (Safety Data Sheets). SDS is provided with unit.



**WARNING :** When installing, maintaining, or removing the fiberglass insulation, the following precautions will minimize airborne dust and fiber:

- Keep personnel not involved in the installation out of the area.
- Use a good vacuum to clean area and equipment. Use a dust suppressant if sweeping is necessary. Do not use compressed air.
- Use a disposable mask suitable for nuisance dust.
- Wear long sleeve clothing, gloves, hat, and eye protection to minimize skin and eye contact. Do not wear contact lenses.
- Thoroughly wash self after work is complete.
- Launder work clothing separate from other clothes and thoroughly clean laundering equipment after use. If clothing contains a large amount of dust and/or fiber, dispose of rather than clean.
- Promptly place used ceramic fiber parts and dust in plastic bags and dispose of properly.

## Standards and Directives

The box furnaces complies with the following standards and guidelines:

### European Union



The European voltage models of this product meet all the applicable requirements of the European Directives and therefore display the CE Marking. The most current EU Declaration of Conformity may be obtained from the manufacturer.

### Product Safety

This product family has been tested to applicable product standards by UL a Nationally Recognized Test Laboratory (NRTL).



## Electromagnetic Compatibility

### FCC Statement (USA)



Any changes or modifications not expressly approved by the party responsible for compliance could void the user's authority to operate the equipment.

NOTE: This equipment has been tested and found to comply with the limits for a Class A digital device, pursuant to part 15 of the FCC Rules. These limits are designed to provide reasonable protection against harmful interference when the equipment is operated in a commercial environment. This equipment generates, uses, and can radiate radio frequency energy and, if not installed and used in accordance with the instruction manual, may cause harmful interference to radio communications. Operation of this equipment in a residential area is likely to cause harmful interference in which case the user will be required to correct the interference at his own expense.

### Canadian ISED IC Notice

This ISM digital apparatus complies with Canadian ICES-001.

Cet appareil ISM est conforme à la norme NMB-001 du Canada.

## South Korean EMC Statement

사용자안내문이기기는업무용환경에서사용할목적으로적합성평가를받은기기로 서가정용환경에서사용하는경우전파간섭의우려가있습니다 .

EMC Registration is done on this equipment for business use only. It may cause interference when the product would be used in home.



## Evaluation of Chemicals - Regulations and Directives

### Proposition 65 - California



**WARNING :** Cancer and Reproductive Harm - [www.P65Warnings.ca.gov](http://www.P65Warnings.ca.gov)

### REACH - Europe

Thermo Fisher Scientific is committed to meeting all compliance obligations to evaluate, communicate, and register any Substances of Very High Concern (SVHC), and finding alternates where appropriate.

### RoHS - Europe

Thermo Fisher Scientific is determined to reduce the impact on the environment, and so can declare that this product fully complies with the European Parliament's RoHS2 (Restriction of Hazardous Substances) Directive 2011/65/EU, with respect to all the following substances:

- Lead (0.1 %)
- Mercury (0.1 %)
- Cadmium (0.01 %)
- Hexavalent chromium (0.1 %)
- Polybrominated biphenyls (PBB) (0.1 %)
- Polybrominated diphenyl ethers (PBDE) (0.1 %)

Our compliance is witnessed by written declaration from our suppliers and/or component testing. This confirms that any potential trace contamination levels of the substances listed above are below the maximum level set by the latest regulations or are exempt due to their application.

## RoHS – China

This product complies with the requirements of the legislative act Administration on the Control of Pollution Caused by Electronic Information Products (ACPEIP). The following label of conformance, may be found on the product:





# Introduction

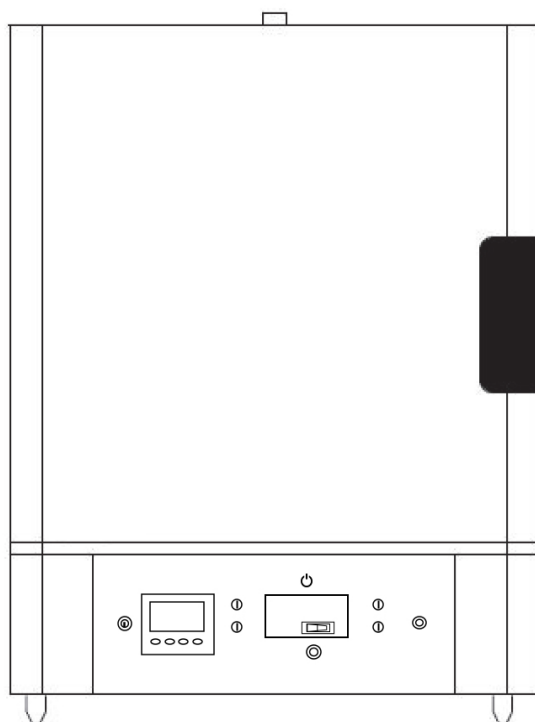

Figure 1 1100°C Box Furnace

Thermo Fisher Scientific 1100°C box furnace series is a family of ultra lightweight, economical, laboratory box furnaces. The low thermal mass Moldatherm<sup>®</sup> insulation/heating element provides fast duty cycles, energy conservation, and efficient programming. Refer to Table Table 1 “1100°C Moldatherm Box Furnace Series” for specifications.

## Features and Benefits

- Controlled heat-up rate eliminates thermal shock to materials.
- Quick heat-up and cool-down rates.
- Four chamber sizes.
- Energy efficient Moldatherm insulation suitable for high interior-exterior temperature differential. The unit is rated for a maximum operating temperature of 1100°C.
- Resists attack from most corrosive agents and can be used in atmospheres other than air.
- Side-hinge door for convenient operation.
- Air vent, standard.
- Atmosphere inlet port standard.

- Digital instrumentation for precise temperature setpoint and display. Microprocessor capable of automatically optimizes control parameters during furnace operation.
- Main power ON/OFF switch on control panel.
- Safety interlock switch automatically interrupts power to heating element when door is opened. This feature protects heating element and eliminates operator's exposure to electrical shock.
- Type K thermocouple.
- Communication option.

## Intended Use

This furnace is intended as a general purpose laboratory, ashing, and heat treating furnace at 1100°C for continuous (over 3 hours) or intermittent (under 3 hours) use, for light industrial and laboratory applications only. The furnace is designed for thermal technology applications in laboratories, such as those found in manufacturing trades and industry, schools, universities and biology. It is used for ageing, analysis, tempering, decomposing, baking, annealing, hardening, soldering, oxidizing, reducing, incineration and preheating.

## Non-Intended Use











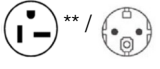



This furnace is not intended for the following:

- To heat up food.
- For drying or heat treatment of substances which release gases or vapors into the atmosphere that are flammable or dangerously explosive when mixed with air.
- This furnace is equally unsuitable for the heat treatment of combustible dusts and fibrous materials.



## Specifications

Table 1 1100°C Moldatherm Box Furnace Series

Model	BF51748 A-1 BF51748COMA-1#	BF51748C-1	BF51766 A-1 BF51766COMA-1#	BF51766C-1	BF51794C-1	BF51728C-1 BF51728RHDC-1
Capacity	2 L (0.07 cu.ft.)	2 L (0.07 cu.ft.)	5.3 L (0.19 cu.ft.)	5.3 L (0.19 cu.ft.)	18.4 L (0.65 cu.ft.)	42.5 L (1.5 cu.ft.)
Temp. Range	100°C to 1100°C	100°C to 1100°C	100°C to 1100°C	100°C to 1100°C	100°C to 1100°C	100°C to 1100°C
Interior (D x W x H)	20.3 x 10.2 x 10.2 cm (4 x 8 x 4 in.)	20.3 x 10.2 x 10.2 cm (4 x 8 x 4 in.)	22.9 x 15.2 x 15.2 cm (9 x 6 x 6 in.)	22.9 x 15.2 x 15.2 cm (9 x 6 x 6 in.)	35.6 x 22.9 x 22.9 cm (14 x 9 x 9 in.)	45.7 x 30.5 x 30.5 cm (18 x 12 x 12 in.)
Exterior (L x W x H)	50.8 x 38.1 x 44.4 cm (20 x 15 x 17.5 in.)	50.8 x 38.1 x 44.4 cm (20 x 15 x 17.5 in.)	53.3 x 43.1 x 54.6 cm (21 x 17 x 21.5 in.)	53.3 x 43.1 x 54.6 cm (21 x 17 x 21.5 in.)	65.4 x 53.3 x 66 cm (25.75 x 21 x 26 in.)	76.2 x 60.9 x 71.1 cm (30 x 24 x 28 in.)
Control	1 program with 8 segments - digital PID control with dual display (referenced as “3216c” in this manual)					
Electrical	120 VAC, 50/60 Hz, 1800 W 1 Phase, 15 A	208/240 VAC, 50/60 Hz, 1800 W 1 Phase, 7.5 A	120 VAC, 50/60 Hz, 1800 W 1 Phase, 15 A	208/240 VAC, 50/60Hz, 1800 W 1 Phase, 7.5 A	208/240 V, 50/60 Hz, 3500 W, 14.6 A	208/240 V, 50/60 Hz, 5600 W, 23.3 A
Shipping Weight	25 kg (55 Lb.)	25 kg (55 Lb.)	50 kg (110 Lb.)	50 kg (110 Lb.)	59 kg (130 Lb.)	84 kg (185 Lb.)
Plug Type	 *	 ** /  **	 *	 ** /  **	 ** /  **	Requires hardwiring by a qualified technician; no wire and plug included; please refer to wiring instructions on page 4-17
Model	BF51848 A-1 BF51848COMA-1#	BF51848C-1 BF51848COMC-1	BF51866 A-1 BF51866COMA-1#	BF51866C-1	BF51894C-1	BF51828C-1 BF51828RHDC-1
Capacity	2 L (0.07 cu.ft.)	2 L (0.07 cu.ft.)	5.3 L (0.19 cu.ft.)	5.3 L (0.19 cu.ft.)	18.4 L (0.65 cu.ft.)	42.5 L (1.5 cu.ft.)
Temp. Range	100°C to 1100°C	100°C to 1100°C	100°C to 1100°C	100°C to 1100°C	100°C to 1100°C	100°C to 1100°C
Interior (D x W x H)	20.3 x 10.2 x 10.2 cm (4 x 8 x 4 in.)	20.3 x 10.2 x 10.2 cm (4 x 8 x 4 in.)	22.9 x 15.2 x 15.2 cm (9 x 6 x 6 in.)	22.9 x 15.2 x 15.2 cm (9 x 6 x 6 in.)	35.6 x 22.9 x 22.9 cm (14 x 9 x 9 in.)	45.7 x 30.5 x 30.5 cm (18 x 12 x 12 in.)
Exterior (L x W x H)	50.8 x 38.1 x 44.4 cm (20 x 15 x 17.5 in.)	50.8 x 38.1 x 44.4 cm (20 x 15 x 17.5 in.)	53.3 x 43.1 x 54.6 cm (21 x 17 x 21.5 in.)	53.3 x 43.1 x 54.6 cm (21 x 17 x 21.5 in.)	65.4 x 53.3 x 66 cm (25.75 x 21 x 26 in.)	76.2 x 60.9 x 71.1 cm (30 x 24 x 28 in.)
Control	5 programs with 16 segments each - digital PID control with dual display (referenced as “3216p” in this manual)					
Electrical	120 VAC, 50/60 Hz, 1800 W 1 Phase, 15 A	208/240 VAC, 50/60 Hz, 1800 W 1 Phase, 7.5 A	120 VAC, 50/60 Hz, 1800 W 1 Phase, 15 A	208/240 VAC, 50/60Hz, 1800 W 1 Phase, 7.5 A	208/240 V, 50/60 Hz, 3500 W, 14.6 A	208/240 V, 50/60 Hz, 5600 W, 23.3 A
Shipping Weight	25 kg (55 Lb.)	25 kg (55 Lb.)	50 kg (110 Lb.)	50 kg (110 Lb.)	59 kg (130 Lb.)	84 kg (185 Lb.)
Plug Type	 *	 ** /  **	 *	 ** /  **	 ** /  **	Requires hardwiring by a qualified technician; no wire and plug included; please refer to wiring instructions on page 4-17

\*Unit is supplied with Cordset per North American (NEMA 5-20P) Plug requirements.

\*\*Unit is supplied with two Cordsets per North American (NEMA 6-20P Plug) and European (EU 1-16P Plug) requirements.

#Unit includes male and female RS 485 Digital Communications DB-9 ports.

NOTE For additional detachable power cord options, see Table 7 “Detachable Power Cord Options”



# Pre-Installation

## Unpacking

Carefully unpack and inspect the unit and all accessories for damage, if you find any damage, keep the packing materials and immediately report the damage to the carrier. We will assist you with your claim, if requested. Do not return goods to Thermo Fisher Scientific without written authorization. When submitting a claim for shipping damage, request that the carrier inspect the shipping container and equipment.

Items enclosed in packaging:

- Hearth Plate
- Gas Inlet Tube
- Exhaust Port Cover
- Power Cord (except 42.5L units)
- User Manual, SDS, User Information Instructions\*

\*NOTE May be contained on optional USB thumb drive.

## Operating Conditions

High concentrations of sulfates, chlorides, fluorides, alkalis, and  $V_2O_5$  can have corrosive effects on the ceramic fiber. Contact Thermo Fisher Scientific for additional information about the effects of specific atmospheres on furnace performance.

With prolonged use, hairline cracks can develop in the insulation materials. These minor cracks will not affect the furnace's performance. It is recommended to turn off the furnace completely when not in use. The heating unit is not damaged by rapid heating and cooling cycles.

## Environmental Conditions

Operating	The recommended ambient temperature is 17°C to 27°C (62.6°F to 80.6°F); 20% to 80% relative humidity, non-condensing. Installation Category II (over-voltage) in accordance with IEC 664. Pollution degree 2 in accordance with IEC 664. Do not exceed ambient temperature of 40°C (104°F).
Altitude Limit	2,000 meters (6561.68 feet).
Storage	-25°C (-13°F) to 65°C (149°F); 20% to 80% relative humidity.

## Atmosphere Systems

The 1100°C box furnace series are not designed for use with combustible or inert atmospheres requiring an air tight chamber. If an exhaust port is used, the furnace should not be located in an enclosed area without proper ventilation.



**WARNING :** Do not use combustible gases directly in this furnace. Process gases must always be contained in a separate tube.



**CAUTION :** Avoid combustible products which generate toxic or hazardous vapor or fumes. Work should only be done in a properly vented environment.

## Installation



**CAUTION :** Be sure ambient temperature does not exceed 40°C (104°F). Ambient above this level may result in damage to the controller. The recommended ambient temperature is 17°C to 27°C (62.6°F to 80.6°F).



**CAUTION :** Allow at least 3" (7.62 cm) of space between the furnace, at least 12" (30.48 cm) above the furnace and any combustible surface. This permits the heat from the furnace case to escape so as not to create a possible fire hazard.



**WARNING :** To avoid electrical shock, this furnace must be installed by a competent electrician who ensures compatibility among furnace specification, power source and ground code requirements.

## Lifting and Carrying



**CAUTION :** Heavy loads. Lift with care!

1. To avoid injury through physical strain, such as strain trauma and slipped discs, do not attempt to lift the furnace alone.
2. To avoid injury through dropped loads, wear Personal Protective Equipment (PPE) per local protocols, such as safety shoes, when lifting the furnace.
3. To avoid crushing your fingers or hands (particularly in a closing door) or damaging the furnace, do not use any other lift points than the bottom sides of the furnace.

## Transport

1. For transport, do not lift the device using the doors or components attached to the device (e.g. control box on rear panel) as lift points.
2. Lift at the bottom sides of the furnace with NIOSH rated straps and/or using appropriate number of personnel per local safety policies and regulations.

## Location

Install the furnace in a level area free from vibration. To permit proper air flow, leave at least 3" (7.62 cm) of space on all sides of the unit and 12" (30.48 cm) above the unit.

## Wiring

For detailed wiring information, refer to:

- Figure 10 "Wiring Diagram (BF51748, BF51766, BF51848 & BF51866)",
- Figure 11 "Wiring Diagram (BF51794, BF51894)" or
- Figure 12 "Wiring Diagram (BF51728, BF51828)".



**WARNING :** Detachable Cordsets cannot be replaced with inadequately rated cords. Before connecting the furnace to the power source, check to see if the power supply voltage corresponds with the specifications on the nameplate on the rear of the furnace.

## 120 VAC Mains Electrical

Models operate on detachable 120 VAC grounded plug and cord set. The units are completely pre-wired ready for operation.

## 208-240 VAC Mains Electrical (excluding BF51728 and BF51828)

Models include a detachable 240 V grounded plug and cord set. The units are completely pre-wired and ready for operation.

A furnace wired for 240 VAC operation can also operate on 208 VAC. 208 VAC heatup and recovery times may be longer than 240 VAC.

## Wiring for BF51728 / BF51828 models

The BF51728 and BF51828 are 208-240 VAC furnaces and do not include a 240 VAC grounded plug and cord set.

Furnace installation requires L1, L2, and ground wire (not provided). The required wire size is 10 AWG for 23.3 Amps @ 240 V.

NOTE For Europe, L2 connection at furnace is wired to Neutral.

NOTE Electrical installation must be performed by a qualified electrician.  
Consult local electrical codes for proper sizing of power and control wiring.

To connect the furnace to the power source, complete the following steps:

1. Determine the length of wire needed to connect the furnace to the power source.
2. Label the power wires Line 1 and Line 2 and label the ground wire Ground.
3. Remove the two outlet box cover screws. Remove the outlet box cover.
4. Use appropriate conduit and clamps for the service wire. Use wire nuts to connect the wires to the appropriate lead wires:

Wire	Label
Line 1	L1
Line 2	L2
Ground	GND

NOTE Unit supplied with 7/8" Hole covered with a bushing that is sized for 1/2" Conduit / connections per electrical standards. Utilize strain reliefs as needed.



**CAUTION :** Failure to check thermocouple wiring connections before initial start up could result in damage to the furnace.

5. Check that all electrical connections are secure.
6. Place the back panel on the furnace and secure with the corner screws.

## Mains Electrical/Thermocouple Check

Before initial start up, inspect the furnace's wiring connections:

1. Remove the corner screws on the back panel of the furnace and detach the back panel.
2. Check that the thermocouple is securely mounted and undamaged.
3. Check the thermocouple wiring connections. Refer to Figure 2 "Thermocouple". Red is always negative.



**CAUTION :** Failure to check thermocouple wiring connections before Initial start up could result in damage to the furnace.

4. Check that all electrical connections are secure. Visually check that the door properly activates the power interrupt switch near the front of the furnace.

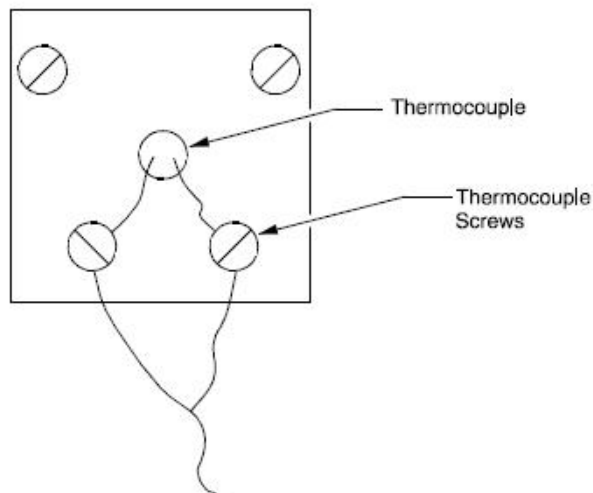

Figure 2 Thermocouple

5. Replace the back panel on the furnace and secure with the corner screws.
6. Connect Mains electrical to facility ground outlet meeting the unit specifications found on the data tag.

## Exhaust Vent

Flow from the exhaust vent on the top of the unit can be adjusted by inserting or removing the plug provided.

For most applications, the exhaust vent should be fully plugged during operation of the furnace; a closed vent results in more efficient operation and greater temperature stability. However, there are some applications which benefit from a partially or fully open exhaust vent.

The exhaust vent should be partially or fully open for the following applications:

- To provide slow cool down of work load. Some work loads may be damaged by heat shock when the furnace door is opened. The vent can be opened to allow work load to cool gradually.
- To remove unwanted vapors and gases from the furnace chamber. If you need to ventilate vapors and gases outside of the room, be sure to read section “Exhaust Port Connections”.

“Exhaust Vents” shows how you can use the plug to adjust flow from the exhaust vent.

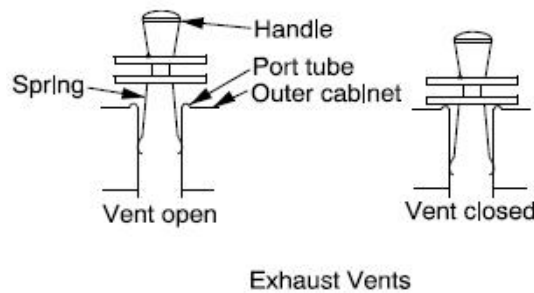

Figure 3 Exhaust Vents

## Exhaust Port Connections

The 1" (2.54 cm) diameter exhaust port through the top wall of the furnace allows for the removal of unwanted vapors and gases produced during high-temperature operation.

When you need to ventilate vapors and gases outside of the room, be sure to make a proper connection to the exhaust port that allows some room air to flow into the exhaust. This is necessary to prevent “chimney effect” which sucks heat out of the chamber and results in slow run-up time or poor temperature uniformity.

Two methods of making the exhaust port connection are shown in “Preventing Chimney Effect”. With a hood suspended above the furnace, be sure that there is at least 3" (7.62 cm) between the hood and the exhaust port. If you use a metal tube or pipe, leave at least 1" (2.54 cm) clearance.



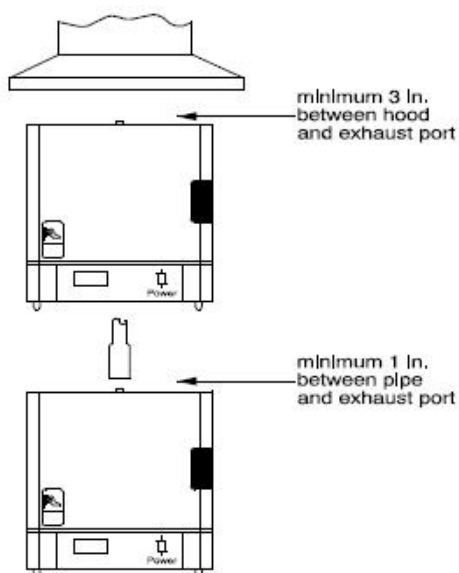

Figure 4 Preventing Chimney Effect

## Atmosphere Inlet

All Moldatherm box furnaces have a factory-installed air/atmosphere inlet.

Most inert atmospheres (i.e. nitrogen, argon, and helium) can be safely run in this box furnace. However, maximum temperatures may be derated depending on atmosphere. An initial burn-in period in air is recommended.

Please contact Thermo Fisher Scientific prior to using the furnace with an inert atmosphere.

The furnace should run for 7 to 10 hours at 1100°C before using an inert atmosphere and after every 60 hours of use with an inert atmosphere. This burn in process will help remove contaminants and provides a protective oxide layer on the heating elements.

This furnace is not designed to be a gas-tight atmosphere furnace.

## Atmosphere Inlet Port

The atmosphere inlet tube assembly has been packaged separately to avoid breakage during shipping and handling.

Even if you do not intend to use the gas inlet, you must install the assembly before operating the furnace. The only tool you need is a Phillips head screwdriver.

To install the atmosphere inlet tube assembly:

1. Carefully remove the assembly from the package and inspect for any damage.
2. Remove the two mounting screws from the rear housing panel of the furnace.
3. Insert the ceramic tube end through the access hole in the rear of the furnace and guide the tube into the back of the chamber.

- Align the mounting holes in the rear housing panel with the holes in the atmosphere inlet port and secure the assembly with the mounting screws.

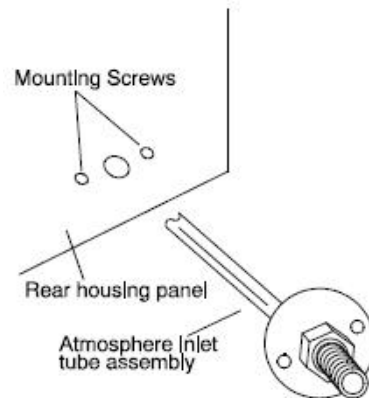

Figure 5 Atmosphere Inlet Port

## Hearth Plate Information



**CAUTION :** Most hearth plate materials are made of ceramic fiber and can be broken if dropped.

### Why to Use

- To provide a load bearing surface and distribute the weight of product being heated.
- To protect the furnace chamber from spillage.
- To lengthen the life of furnace, by allowing heat from the chamber floor to circulate into the chamber center.

### When to use

- Hearth plates are recommended during each furnace operation.

### How to Install

- Hearth plates are designed with grooved surface.
- The grooved surface must be positioned facing the chamber floor.

# Start-Up



**WARNING :** After transport and decommissioning, or storage under humid conditions a drying-out process must be performed due to hygroscopic nature of the ceramic fiber insulation. During the drying-out process the equipment cannot be assumed to meet all the safety requirements of the IEC 61010-2-010 standard.











**WARNING :** Observe the following precautions when operating the furnace:

- Never stand in front of an open furnace.
- Wear protective eyewear.
- Wear protective gloves.
- Use tongs to insert and remove furnace load.
- Do not allow the load to touch the furnace walls.
- Always use a hearth plate on the furnace bottom.

## Initial Furnace Start-Up/Drying-Out Process

The furnace has a power interrupt switch. Opening the furnace door shuts off power to the heating unit. The door must be completely closed before the furnace will operate.

To start up the furnace, complete the following steps:

1. Turn the furnace ON.
2. Press the  SCROLL button until set point SP1 is displayed. Press  UP or  DOWN key until 200 is indicated on the display.
3. Run the furnace for 2 hours after reaching 200°C.
4. Check for heat loss through the door. In the event of heat loss, recheck the door seal. (Refer to section “Door Seal Check”).
5. If no heat loss is detected, then press the  SCROLL button until set point SP1 is displayed. Press  UP or  DOWN button until 550 is indicated on the display.
6. Run the furnace for 2 hours after reaching 550°C.
7. Check for heat loss through the door. In the event of heat loss, recheck the door seal. (Refer to section “Door Seal Check”).
8. If no heat loss is detected, then press the  SCROLL button until set point SP1 is displayed. Press  UP or  DOWN button until 1000 is indicated on the display.
9. Run the furnace for 2 hours after reaching 1000°C.
10. Check for heat loss through the door. In the event of heat loss, recheck the door seal. (Refer to section “Door Seal Check”).
11. Adjust the set point SP1 to room temperature.

- Highly recommended to Auto Tune unit for application prior to use refer to section “Auto Tuning” .

Refer to section “Eurotherm 3216 Controller” for detailed start up steps.

## Door Seal Check

It is very important to check the door seal before using this furnace. Door seal integrity is essential to maintain temperature uniformity and to prevent fumes being released into the area surrounding the furnace.

To check the door seal:

- With the furnace power off and the chamber cold, open the door.
- Insert a strip of paper (a couple of inches wide) between the door insulation and the chamber opening. Do not position the paper in the corner of the chamber. Close the door.
- Slowly pull the paper strip from the outside. You should feel some resistance. If the paper does not pull out, this area of the door seal may be too tight, causing a gap in another area of the door seal.
- Repeat this test at 2" (5.08 cm) intervals around the door. If the door does not seal properly, a door adjustment must be done. Refer to section “Door Seal Adjustment (if necessary)” .

## Door Seal Adjustment (if necessary)

To adjust the door seal:

- Door assemblies have hex nuts attaching the insulation frame to the outer door frame. Loosen the appropriate nuts and move the door insulation frame to improve the door seal.

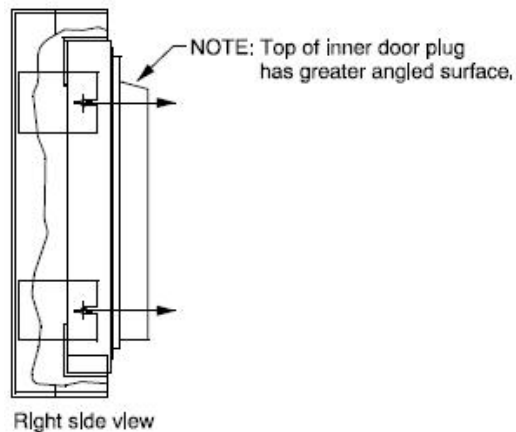

Door Insulation Replacement

- Recheck the door seal, following the instructions in the section “Door Seal Check” .
- If a gap is detected only in the center top edge of the door seal, then the top corners of the sealing surface of the door may be sanded to lessen the center gap.

4. After each adjustment recheck the door seal.

The door seal has been adjusted properly if there is no heat loss when operating the furnace up to 500°C.



**WARNING :** When installing, maintaining, or removing the fiberglass insulation, the following precautions will minimize airborne dust and fiber:

- Keep personnel not involved in the installation out of the area.
- Use a good vacuum to clean area and equipment. Use a dust suppressant if sweeping is necessary. Do not use compressed air.
- Use a disposable mask suitable for nuisance dust.
- Wear long sleeve clothing, gloves, hat, and eye protection to minimize skin and eye contact. Do not wear contact lenses.
- Thoroughly wash self after work is complete.
- Launder work clothing separate from other clothes and thoroughly clean laundering equipment after use. If clothing contains a large amount of dust and/or fiber, dispose of rather than clean.
- Promptly place used ceramic fiber parts and dust in plastic bags and dispose of properly.



# Main Controller: 1x8 & 5x16 Segment Programmable

## Eurotherm 3216 Controller

The Eurotherm 3216c and 3216p temperature controllers sense the furnace's chamber air temperature (the PV or process value) and provides the heat needed to reach the required set point.

There are two choices of controls used in the various furnaces models: The 3216c controller is a basic single setpoint and Timer (1-program 8-segment or Dwell timer or Delay timer). The 3216p controller offers single setpoint and 5-program 16-segment, this controller can store up to 5-different programs and each program can contain up to 16 segments.

This chapter provides brief instructions on various controller operations which include:

- Setting target temperature
- Setting the ramp rate
- Changing display units
- Auto tuning the controller
- Setting over – temperature protection (OTP)
- Temperature offset procedure
- Timer operation (3216c controller only)
- 5x16 programmer operation (3216p controller only)



**CAUTION :** Before operating the controller, read this chapter carefully. Wrong procedures can change the unit characteristics and design parameters, which can hamper performance and make the equipment dangerous to use.

The furnace temperature controller is configured and tuned at the factory to function well for most applications. Occasionally, it may be advisable to configure the temperature controller differently to suit a particular working environment or process.

## Operator Interface & HOME Display

When the controller is turned ON, it will perform a brief self-test and then display the HOME Display page. The measured value (process value) is found in the upper display and the set point is found in the lower display.

The description of interface beacons and buttons are shown in “Beacon Display and Description” & “Operator Buttons” respectively.

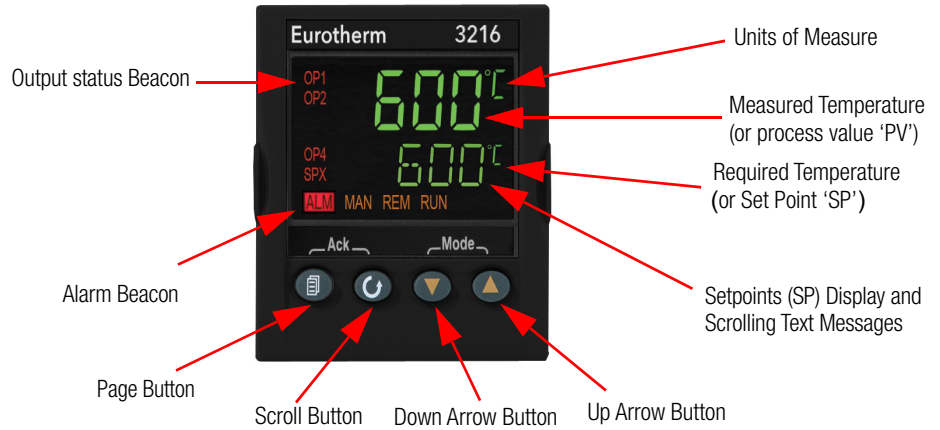

## Beacon Display and Description

OP1 (Output 1)	Illuminates when the output to heater
OP4 (Output 4)	Illuminates when the output is ON (Over-temperature alarm).
SPX	Alternative set point in use (SP2)
ALM	Alarm active (Red)
REM	Remote set point or communication active
RUN	Timer running for 3216c or Program running for 3216p
RUN (flashing)	Timer hold for 3216c or Program hold for 3216p



## Operator Buttons



Press to select a new list of parameters and from any display - press PAGE to return to the HOME Page



Press to select new parameter from the page header. If held down it will continuously scroll through parameters.

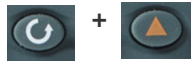

Hold down SCROLL and press UP ARROW to scroll back parameters.



Press to decrease or change the state of a value.



Press to increase or change the state of a value.



## Single Set Point Operation

3216 controller has capability to select set point-1 and set point-2. User can setup two different set points to select the desired set point, SP.SEL function can be used.

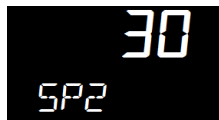
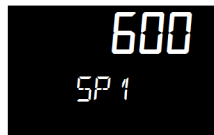

To set the desired temperature set point, complete the following steps:

1. Press the SCROLL  button until SP1 or SP2 is displayed.



2. Press UP  or DOWN  button until the desired setpoint is displayed and then release the button. A few seconds after the button is released, the controller will accept the new value and is indicated by a brief flash of the display.
3. Press PAGE  button to return to the HOME display.

## Alternate Set Point Selection (SP2)

1. Press the SCROLL  button from HOME display until SP.SEL is displayed.
2. Press UP  or DOWN  button to select SP1 or SP2.

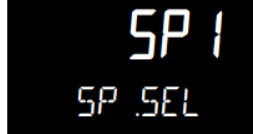

If SP2 is selected, then SPX beacon will appear on the HOME display indicating the action of alternate set point in use.





## Set Point Ramp Rate

The ramp rate SP.RAT is designed to reduce the heating rate that the furnace normally exhibits. When SP.RAT is 'OFF', the furnace will operate at its maximum heating capability. But if ramp rate feature is used, then the chamber is heated at any rate slower than the maximum capability of the unit. To fine tune ramp rates, you may need to test the furnace using loads that you intend to use in furnace application or with loads having similar mass and thermal properties.

**NOTE** If ramp rate exceed the capability of the furnace unit, it will run the max 100% output of heater capacity. If ramp rate value set less than 100%, furnace unit heater output is reduced and furnace unit chamber gets heated slowly.

Complete the following steps to set the ramp rate units:

1. The ramp rate units can be set in seconds, minutes or hours.
2. Press the SCROLL  button until RAMPU is displayed.
3. Press UP  or DOWN  button until the desired ramp rate unit is indicated on the display.





4. The new ramp rate unit is applied when the button is released and is indicated by a brief flash of the display.
5. Press PAGE  button to return to HOME display.

Complete the following steps to change the ramp rate of SSP.

6. Press the SCROLL  button until SP.RAT is displayed.



7. Press UP  or DOWN  button until the desired ramp rate is indicated on the display. The unit of ramp rate depends on the type of ramp unit RAMPU selected.





8. The new ramp rate is applied when the button is released and is indicated by a brief flash of the display.
9. Press PAGE  button to return to HOME display.

## View or Change the Display Units

To change the temperature scale in 3216 controller to operate on °F instead of the factory setting of °C, or to change from °F to °C, follow these steps.

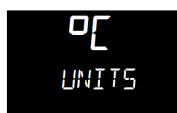
1. Press the SCROLL  button until "UNITS" is shown in the lower display. The current unit is shown in the upper display.



2. Press UP  or DOWN  button to change the display unit.
- a. (°C): Degrees Celsius

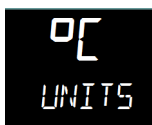

- b. (°F): Degrees Fahrenheit

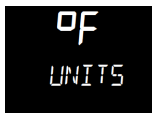

- c. (°K): Kelvin



- d. (NONE): No units displayed



- e. (PERC): Percent



**NOTE** Do not use nonE & PERc, they are used to measure other applications types other than temperature.

## Auto Tuning

In Auto Tuning the characteristics (PID parameters) of the controller are matched to the characteristics of the product load in order to obtain good control.

Good control means:

- Stable control of the set point
- No overshoot or undershoot
- Quick response to deviations from the set point
- Removal of fluctuations



The 3216 controller uses a one-shot tuner which automatically sets the initial values of the parameters listed in Table 2 “Parameter Description and Accessibility in 3216c” and Table 3 “Parameter Description and Accessibility in 3216p”.

Thermo Fisher recommends that you tune the furnace to your specific application to obtain the best results.

## Steps to Auto Tune the Controller

1. Load the chamber with materials that have the same mass and thermal characteristics as a typical product load.
2. Set the temperature as per requirement; refer to section “Single Set Point Operation” on setting SP1 or SP2.
3. Press SCROLL  button to scroll through the list of parameters until A.TUNE is displayed.



4. To enable the auto-tune, set the A.TUNE parameter to ON by using DOWN  or UP  button.
5. Press the PAGE  button to return to the HOME display. The display will flash TUNE to indicate that tuning is in progress.



The auto tune is completed when the regular display of the measured temperature is shown and the process is allowed to control at the target set point using the new control terms.

#### NOTE

- If the process temperature or load changes significantly another auto tune session may be necessary to optimize the chamber performance.
- If the controller is auto tuning and sensor break occurs, the auto tune will abort. Auto tune must be re-started when the sensor break condition is no longer present.
- If an Auto tune cannot be performed an error message, Etun will be flashed in the display.
- Auto tune will not work when controller is running program or Timer.

## Parameter List

Parameters are available under different levels of security and are defined as Operator Level 1 (LEv1) & Operator Level 2 (LEv2). This section describes various parameters used in each operator levels.

### Operator Level 1



Operator level 1 is designed for day to day operation of the controller and parameters are not protected by a security code. From HOME display, press SCROLL  button to scroll through the list of parameters in Level 1.

The parameter mnemonic and its scrolling description are shown in the lower display. The value of the parameter is shown in the upper display. After 5 seconds, a description of the parameter will scroll once along the display and then revert back to the mnemonic. The scrolling text can be interrupted at any time by a single press of any of the buttons, but will not scroll again until the parameter is returned to.

## Operator Level 2

Operator Level 2 provides access to additional parameters and this access is protected by a security code. The Level 2 access should typically be granted to a specially trained person, since changing parameters can have major impact on the temperature performance of the furnace. After entering Level 2, press SCROLL  button to scroll through the list of parameters. Like Level 1, the mnemonic of the parameter is shown in the lower display, followed once by a scrolling help message showing a longer description of the parameter. The value of the parameter is shown in the upper display.



Press DOWN  or UP  button to adjust this value. If no button is pressed for about 30 seconds, the display returns to 'HOME Display'.

Back scroll is achieved when you are in the list by pressing UP  button while holding DOWN  and SCROLL  button.

## To Enter Level 2

1. From any display press and hold PAGE  button.
2. After a few seconds the display will show 'LEv 1 GOTO'.



3. Release SCROLL  button. (If no button is pressed for about 45 seconds the display returns to the HOME Display).
4. Press the UP  or DOWN  button to choose LEv2 (Level 2).



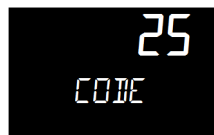

5. Press UP  or DOWN  button to enter the password. The default code is '25'.



If an incorrect code is entered the display reverts to Level 1.

## To Return to Level 1

1. Press and hold PAGE  button to show the current operator level.
2. Press UP  or DOWN  button to select LEv 1.



When Level 1 is selected the display reverts to the HOME display. A passcode is not required when moving from a higher level to a lower level.

## Offset Procedure

All ranges of the controller have been calibrated against traceable reference standards. This means that if the input type is changed it is not necessary to calibrate the controller. There may be occasions, however, when you wish to apply an offset to the standard calibration to take account of known errors within the process, for example, a known sensor error or a known error due to the positioning of the sensor. In these instances it is not advisable to change the reference (factory) calibration, but to apply a user defined offset.

PV Offset applies a single offset to the temperature or process value over the full display range of the controller and can be adjusted in Level 2. It has the effect of moving the curve up or down about a central point as shown in the example below:-

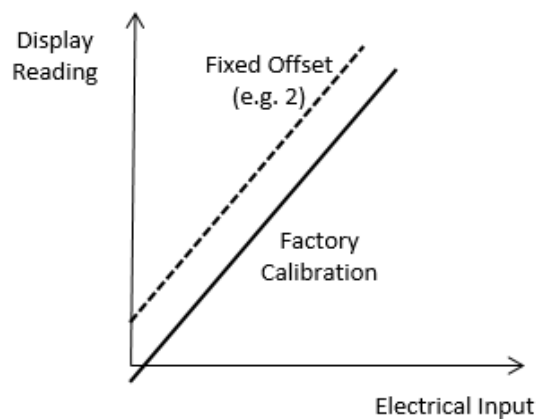

## To Apply an Offset

Connect the input of the controller to the source device which you wish to calibrate to. Set the source to the desired calibration value. The controller will display the current measurement of the value. If the display is correct, the controller is correctly calibrated and no further action is necessary. If you wish to offset the reading:

1. Enter Level 2; refer to section “To Enter Level 2” for steps to enter Level 2.
2. Press SCROLL  button to scroll through the parameter list until ‘PV.OFS’ displayed.

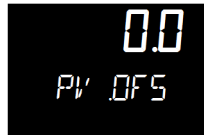

3. Press UP  button or DOWN  button to set the required offset value.

## Alarms & Diagnostics



Alarms are used to alert an operator when a pre-set level has been exceeded. They are indicated by a scrolling message on the display and the red ALM beacon.

### Alarm Indication & Acknowledgment

Alarm Indication & Acknowledgement should go before Sensor Break.

- If an alarm occurs the red ALM beacon will flash, a scrolling message will give the source of the alarm and the alarm (relay) output will operate. A typical default message will show the source of the alarm followed by the type of alarm. For example, ‘ALARM 1 FULL SCALE HIGH’. If more than one alarm is present further messages are flashed in turn in the main display. The alarm indication will continue while the alarm condition is present and is not acknowledged.
- ALM beacon on continuously = alarm has been acknowledged.



- Press PAGE  button and SCROLL  button together to acknowledge an alarm. If the alarm is still present the ALM beacon lights continuously.

The action which takes place depends on the type of alarm configured:



## Sensor Break & Loop Break Protection

Sensor Break Protection - The controller provides sensor break protection in the event the thermocouple opens. If an open thermocouple condition occurs, the digital display will blink "S.br", a red alarm beacon will be illuminated and the power to the heating element will be shut off.

Loop Break alarm is displayed as CONTROL LOOP BROKEN. This occurs if the controller does not detect a change in process value following a change in output demand after a suitable delay time. Since the time of response will vary from process to process the Loop Break Time parameter 'LBT' allows a time to be set before a loop break alarm is initiated. In these circumstances the output power will drive to high or low limit. For a PID controller, if the PV has not moved by  $0.5 \times P_b$  in the loop break time the loop is in break.

The loop break time is set by the AutoTune, a typical value is  $12 \times T_d$ . The loop break alarm may be disabled by setting its time to Off.

## Over-Temperature Protection (OTP)



The over-temperature protection will be in effect during any alarm condition when the temperature of the furnace has deviated beyond the limit. The Deviation High alarm is triggered when the measured temperature becomes higher than the set point by the amount of the threshold/deviation. Thermo Fisher recommends a value of  $50^\circ\text{C}$  above your working temperature to provide protection for your workload.

In certain units, full scale high alarm 'Hi' is also present. Full scale high alarm will be detected if the PV value exceeds the full alarm trip level.

### To Configure Deviation High Alarm

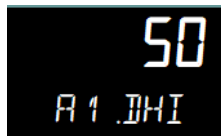
1. Press SCROLL  button until "A1.DHi" appears on the display.



2. Press UP  or DOWN  button to select the OTP value you desire. We recommend a value of 50.

## Program/Timer Segment Types

In program ON condition each segment consists of a controlled ramp rate to a target set point followed by a dwell at that set point. These values can be set by the user.

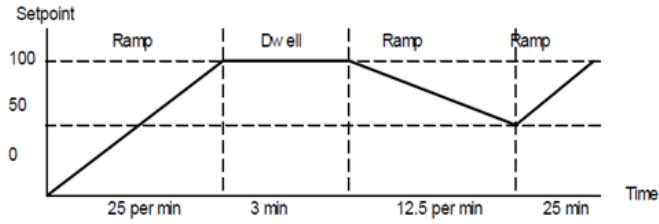

a. Target set point

Target set point will ramp from the current value of the measured temperature to the target set point value based on ramp rate.

b. Ramp Rate

A Ramp segment provides a controlled change of set point from an original to a target set point. The duration of the ramp is determined by the rate of change specified. The segment is specified by the target set point and the desired ramp rate. The ramp rate parameter is presented in engineering units (°C, °F, Eng.) per real time units (Seconds, Minutes or Hours). If the units are changed, all ramp rates are re-calculated to the new units.



c. Step

The set point changes instantaneously from its current value of the measured temperature to a new value at the beginning of a segment. Step can be achieved by turning off Ramp rate. A Step segment has a minimum duration of 1 second.



d. Dwell

The set point remains constant for a specified period at the specified target. The operating set point of a dwell is inherited from the previous segment.



## Remaining Time

Time remaining before the dwell segment completes.

**NOTE** For all modes except the setpoint programmer, the time remaining may be edited while the program is running, in this case the program duration is modified immediately. This is useful for extending or shortening the duration of a batch.

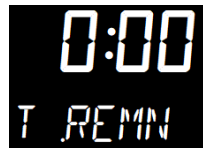

## Elapsed Time

The time elapsed since the Program/Timer was activated.

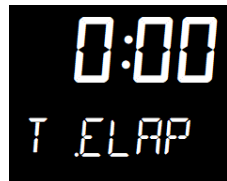

## 1-Program 8-Segment Controller Operation

An internal timer in 3216c controller can be configured to operate in four different modes:

- Dwell at temperature. This may be used in combination with the set point ramp limit to provide a simple ramp/dwell temperature sequence.
- Delayed switch on timer. This may be used to implement a switch on delay, and often eradicates the need for a separate timer device.
- Soft Start timer. Starts automatically on power up. It applies a power limit until the temperature reaches a threshold value or the timer times-out after the dwell period.
- 8-Segment programmable controller (4 ramps & 4 soaks).

The 8-segment programmable 3216c controller consists of microprocessor based three-mode PID (Proportional, Integral and Derivative) and appropriate output switching devices to control the furnace. The programmable controller can be used as a single set point controller or as a programmable controller. The 8-segment digital model enables eight segments of programming. The controller is capable of varying temperature or process value with time through programming. A program is stored as a series of segments and can be run once.

Some of the commonly used parameters in operator Level 1 and Level 2 of 3216c controller are:

**Table 2** Parameter Description and Accessibility in 3216c

No.	Parameter	Description	Level	Access	Value	Page No.
1	T.STAT	Timer Status	Level 1 + 2	Read/Write	rES	6-39
2	T.REMN	Timer Remaining	Level 1 + 2	Read Only	-	6-32
3	T.ELAP	Elapsed Time	Level 1 + 2	Read Only	-	6-33
4	A1.DHI	Deviation High Alarm Set Point	Level 1	Read/Write	50	6-31
5	A2.HI	High Temperature Alarm Set Point	Level 2	Read Only	1125	6-31
6	SP.SEL	Set point Select	Level 1 + 2	Read/Write	SP1	6-23
7	SP1	Set point 1	Level 1 + 2	Read/Write	0-1100	6-24
8	SP2	Set point 2	Level 1 + 2	Read/Write	0-1100	6-24
9	RAMPU	Set point Ramp Units	Level 1 + 2	Read/Write	Mins	6-24
10	SP.RAT	Set point Rate Limit	Level 1 + 2	Read/Write	Off	6-25
11	A.TUNE	Auto Tune Enable	Level 1 + 2	Read/Write	Off	6-26
12	UNITS	Display Units	Level 1 + 2	Read/Write	Deg C	6-26
13	TM.CFG	Timer Configuration	Level 1 + 2	Read/Write	Prog(10)	6-38
14	SS.SP	Soft Start Setpoint	Level 1 + 2*	Read Only*	-	6-35
15	SS.PWR	Soft Start Power Limit	Level 1 + 2*	Read Only*	-	6-35
16	T.T	Requested Time Duration	Level 1 + 2*	Read Only*	-	6-35
17	THRES	Timer Start Threshold	Level 1 + 2	Read/Write	1	6-36
18	END.T	Timer End Type	Level 1 + 2	Read/Write	Dwell	6-37
19	Timer.TimeRes	Timer resolution	Level 1	Read Only	Mins	6-36
<b>20</b>			Level 2	Read/Write		6-36
21	TSP.1 to TSP.4	Target Set point 1 to Target Set point 4	Level 2	Read/Write	550	6-38
22	RMP.1 to RMP.4	Ramp Rate 1 to Ramp Rate 4	Level 2	Read/Write	OFF	6-38
23	DWEL.1 to DWEL.4	Dwell Time 1 to Dwell Time 4	Level 2	Read/Write	1 hour	6-39
24	PB	Proportional Band	Level 2	Read/Write	15	-
25	TI	Integral Time	Level 2	Read/Write	95	-
26	TD	Derivative Time	Level 2	Read/Write	16	-
27	LBT	Loop Break Time	Level 2	Read/Write	30 mins	6-31
28	PV.OFS	PV Offset	Level 2	Read/Write	0	6-30

No.	Parameter	Description	Level	Access	Value	Page No.
29	ADDR**	Comms Address	Level 2	Read/Write	1	7-48
30	BAUD**	BAUD RATE	Level 2	Read/Write	9600	7-48
31	IN.TYP	Input Type	Level 2	Read Only	K Type Thermocouple	-
32	ID	Customer ID	Level 2	Read Only	303 (without COMMS) 304 (with COMMS)	-

\*Level 1+2 Read Only states that, Level 1 gives Read only access to user where as Level 2 gives Write access along with Read access.

\*\*COMMS units only

## Soft Start Timer

The timer is used to start a process at reduced power and/or reduced setpoint. It may be used where it is required to dry out a heater before applying full power, such as hot runner applications.

It is initiated by any one of the following:

- Switching on power;
- Pressing ▲ and ▼ together;
- Setting the parameter T.STAT to run;
- A command through serial communications;
- A logic input suitable configured.

When the timer status = run, the control output is limited to a reduced start up power until parameter SS.SP is exceeded. If the PV is already greater than SS.SP the reduced power limit is not applied and the timer times out.

When the timer status = reset, the control output is controlling at a level limited by the output high and low limits.

## Soft Start Setpoint

A soft start timer is provided to control start-up of sensitive heaters. If these heaters are stressed by applying 100% power from cold they could be damaged. The soft start facility introduces a power limit until either the safe operating temperature (SS.SP) is reached or a time duration has elapsed (TIME).

The SS.SP is the threshold for the soft-start timer. If the PV is below this value at power up then the soft start timer is started.

## Soft Start Power Limit

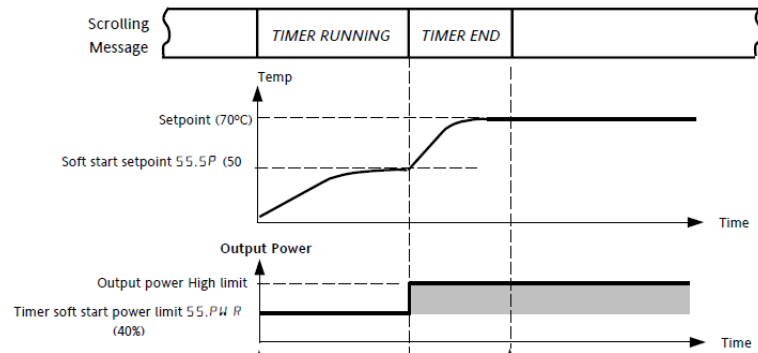

The soft start function limits the power delivered to the heater until it has warmed up. The SS.PWR is the power limit applied until the PV reaches the SS.SP or the timer has elapsed.



## Delayed Switch On Timer

The timer is used to switch on the controller output power after a fixed length of time. It could be used to turn on a process at a particular time.

It is initiated by any of the following:

- Switching on power;
- Momentarily pressing  and  together;
- Setting the parameter T.STAT to run;
- A command through serial communications;
- A logic input suitably configured.

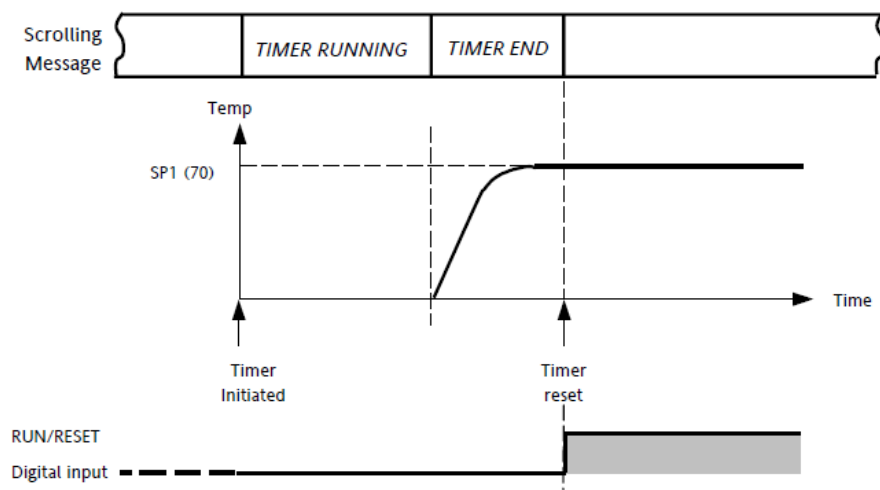

When the timer status = run, the control output is off.

When the timer status = reset, the control output is controlling.



## Timer Start Threshold

A single threshold value is available to provide a holdback on the entry to the dwell part of the ramp/dwell pair. It holds back the dwell until the PV has reached the band defined by +/- threshold around the PV. The timer starts timing when the temperature is within this threshold of the setpoint. This provides a guaranteed soak temperature. The threshold can be set to Off (0) in which the threshold is ignored and the timing starts immediately. Note that if a ramp rate is set, the ramp completes before timing starts.

To set the threshold value, press SCROLL  button until 'THRES' is displayed. ("THRES" can be accessed from Level 1 and Level 2). Press UP  or DOWN  button to adjust the value (In the example given below, the dwell periods will not start until the PV is within 5 units of the set point).

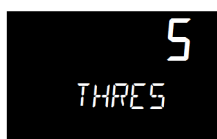

## Timer as 8-Segment Programmer

A sample program profile of 3216c is shown in the diagram below. It is an 8 segment programmer consisting of four ramp/dwell pairs. Each ramp consists of a controlled rate of change of set point to a target level. Each ramp is followed by a dwell at that level. The ramp rate, target level and dwell time are set by the user.

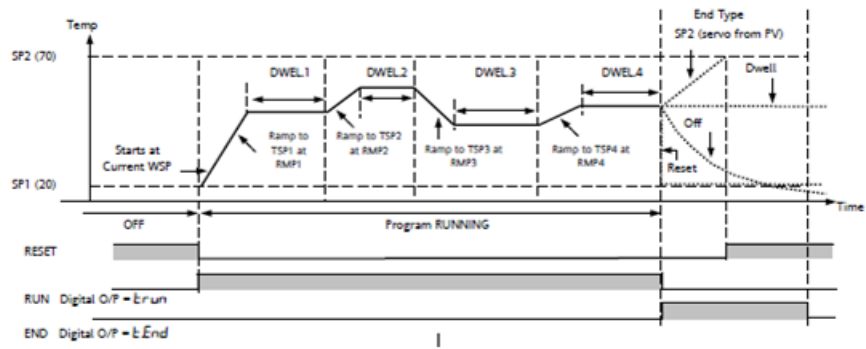

### End Type parameter

The action which occurs at the end of program or in reset depends on the configuration of the 'END.T' parameter. The 'END.T' can be:

**OFF** : The heating is turned OFF.

**dwEll** : Controls at last program setpoint.

**SP2** : Controls at setpoint 2 (When the timer completes the target setpoint will switch to setpoint 2. The setpoint 2 may be a lower or a higher temperature.).

**rES** : Reset on completion and reverts to SP1 or SP2, based on the setpoint selection.

SCROLL (G) through parameters in level 2 and set the required 'END.T' by pressing (▲) or (▼).



### To Configure the Programmer



1. Enter level 2 to configure the timer as a programmer. Press SCROLL (G) button to scroll through the list of parameters until 'TM.CFG' is displayed. Now, press DOWN (▼) or UP (▲) button to select 'PROG'.





2. To set the resolution, press SCROLL (G) button to select 'TM.RES'. Press DOWN (▼) or UP (▲) button to set 'Hour' or 'min' (In this example, the ramp rate and dwell period are set in hours).









3. Now set the threshold by pressing SCROLL  button to select '**THRES**'. Press UP  or DOWN  button to adjust the value (In this example, the dwell periods will not start until the PV is within 5 units of the set point).

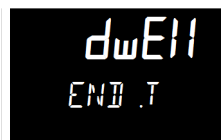



4. Now, set the action when the programmer times out. Press SCROLL  button to select '**END.T**' is displayed. Press UP  or DOWN  button to select 'Off or 'SP2' or 'Dwell' (This example uses 'dwell' where the controller will continue to control indefinitely at the last set point. OFF will turn the output power off and SP2 will control at set point 2).



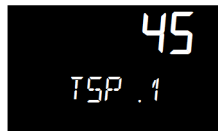

5. To set the first target set point, press SCROLL  button to select '**TSP.1**'. Press UP  or DOWN  button to adjust the value (In this example the set point will ramp from the current value of the PV to the first target 45°C).

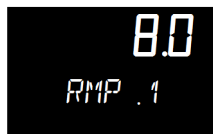

6. To set the first ramp rate, press SCROLL  button to select '**RMP.1**'. Press UP  or DOWN  button to adjust the value to 8. (In this example the set point will ramp to 45 at 8.0 units per hour).









7. To set the first Dwell, press SCROLL  button to select '**DWEL.1**'. Press UP  or DOWN  button to adjust the value to 2:11. (In this example the set point will dwell at 45 for 2 hours 11 minutes).



8. Now repeat the above three steps (5, 6 & 7) to set remaining all segments.

## To Operate the Programmer

Operation	Action	Indication
To Run a program	Press and quickly release  + 	Beacon RUN = On Scrolling display - TIMER RUNNING
To Hold a program	Press and quickly release  + 	Beacon RUN = Flashing Scrolling display - TIMER HOLD
To Reset a program	Press and hold  +  for more than 1 second	Beacon RUN = Off If End Type = Off then OFF will be displayed at the end of the program
	Program ended	Beacon RUN = Off SPX On if End Type = SP2 Scrolling display – TIMER END

Programs can also be operated from the **'T.STAT'** parameter found in the level 1 parameter list.

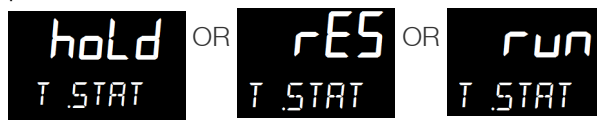



### NOTE

- The program ramp rate is designed to reduce the heating rate or cooling rate that the furnace normally exhibits. When not using this feature, the furnace will operate at its maximum heating and cooling capability.
- When the program ramp has ended or has been reset, the furnace will continue to maintain set point temperature. It will not cool to ambient temperature unless the set point is set to ambient temperature by the program or by the operator.
- When a step change is required, the ramp rate should be set to 'OFF'.
- Where ramp/dwell pairs are not required, the ramp rate should be set to 'OFF' and the target set point, TSP, the same as the preceding segment.
- TIMER END- when the end type is SP2, Timer END does not occur until the ramp is complete or SP2 is achieved. It is more usual to use a DWELL (default) or RESET end type.
- The program will start from the measured temperature. On recovery from power failure, the program will automatically run at the last ramp rate from the current measured temperature.

## AUTO/MAN/OFF: (Auto/Manual/OFF Mode)



**CAUTION :** Thermo Fisher Scientific does not recommend to use controller in MANUAL mode or OFF mode, as Manual mode can damage the unit or cause over-heating without care or proper operation. If controller set as MANUAL mode operation, the end user must use a separate 'over-temperature' controller for safe operation of the unit.

Operation	Action	Indication
To change Auto to Manual model	Press and hold  +  for more than 3 seconds	Controller display Shows Auto mode as A-M.

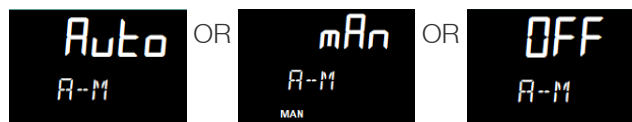

1. **AUTO:** When the controller is in the automatic mode the output automatically adjusts to keep the temperature or process value at the setpoint. Auto mode is also referred to as “closed loop” as the controller will use thermocouple temperature as feedback to control the furnace temperature.
2. **MAN:** Manual mode means that the controller output power can be adjusted directly by the user. The input sensor is still connected and reading the PV but the control loop is ‘open’. In manual mode the MAN beacon will be lit, Band and deviation alarm are masked, the auto-tuning timer and programmer functions are disabled. The power output can be continuously increased or decreased using the up or down buttons.
3. **OFF:** Off mode means that the heating and cooling outputs are turned off. The process alarm and analogue retransmission outputs will however, still be active while Band and deviation alarm will be OFF.

## 5-Program 16-Segment Controller Operation

The 3216p temperature process controller is a single loop PID based controller that can store up to 5 programs with 16 segments each. This controller consists of microprocessor based three-mode PID (Proportional, Integral and Derivative), programmable temperature controller and appropriate output switching devices to control the furnace. The programmable controller can be used as a single set point controller or as a programmable controller. The controller is capable of varying temperature or process value with time through programming. A program is stored as a series of segments and can be run once. This 16 segment digital model can enable 16 segments in each program.

Some of the commonly used parameters in operator Level 1 and Level 2 of 3216p controller are:

Table 3 Parameter Description and Accessibility in 3216p

No.	Parameter	Description	Level	Access	Value	Page no.
1	P.STAT	Program Status	Level 1 + 2	Read/Write	Reset	6-45
2	T.REMN	Timer Remaining	Level 1 + 2*	Read Only	-	6-35
3	T.ELAP	Elapsed Time	Level 1 + 2*	Read Only	-	6-35
2	A1.DHI	Deviation High Alarm Set Point	Level 1	Read/Write	50	6-31
3	A2.HI	High Temperature Alarm Set Point	Level 2	Read Only	1125	6-31
4	SP.SEL	Set point Select	Level 1 + 2	Read/Write	SP1	6-23
5	SP1	Set point 1	Level 1 + 2	Read/Write	0-1100	6-24
6	SP2	Set point 2	Level 1 + 2	Read/Write	0-1100	6-23
7	RAMPU	Set point Ramp Units	Level 1 + 2	Read/Write	Mins	6-24
8	SP.RAT	Set point Rate Limit	Level 1 + 2	Read/Write	Off	6-25
9	A.TUNE	Auto Tune Enable	Level 1 + 2	Read/Write	Off	6-26
10	UNITS	Display Units	Level 1 + 2	Read/Write	Deg C	6-25
11	PROG	Current Program Number	Level 1 + 2	Read/Write	1 to 5	6-35
12	END.T	Program End Type	Level 1 + 2	Read/Write	Dwell	6-43
13	H.BACK	Program Holdback	Level 1 + 2	Read/Write	1	6-42
14	DWEL.U	Dwell Units	Level 1	Read Only	Mins	6-44
15			Level 2	Read/Write		6-44
16	TSP.1 to TSP.8	Target Set point 1 to Target Set point 8	Level 2	Read/Write	550	6-44
17	RMP.1 to RMP.8	Ramp Rate 1 to Ramp Rate 8	Level 2	Read/Write	OFF	6-44
18	DWEL.1 to DWEL.8	Dwell Time 1 to Dwell Time 8	Level 2	Read/Write	1 hour	6-45
19	PB	Proportional Band	Level 2	Read/Write	15	-
20	TI	Integral Time	Level 2	Read/Write	95	-
21	TD	Derivative Time	Level 2	Read/Write	16	-
22	LBT	Loop Break Time	Level 2	Read/Write	Off	6-31
23	PV.OFS	PV Offset	Level 2	Read/Write	2	6-30
24	ADDR**	Comms Address	Level 2	Read/Write	1	7-48
25	BAUD**	BAUD RATE	Level 2	Read/Write	9600	7-48
26	IN.TYP	Input Type	Level 2	Read Only	K Type Thermocouple	-
27	ID	Customer ID	Level 2	Read Only	303 (without COMMS) 304 (with COMMS)	-

\*Level 1+2 Read Only states that, Level 1 gives Read only access to user where as Level 2 gives Write access along with Read access.

\*\*COMMS units only

## Holdback Function



The temperature ramp rate of the program is quicker than the furnace can achieve. the program will wait until the temperature of the furnace catches up. e.g. If a holdback value of 10 is set and the program is set to ramp to a set point of 600°C, the program will reach 600°C, then go into an hold state; the hold indicator will light until the furnace or oven temperature reaches 590°C, the program will then continue to control again.

The holdback will only apply once per Segment, therefore when control has been reestablished, the holdback will not apply again to that segment, even if the furnace or oven temperature go outside the holdback band. Each program can have its own Holdback value assigned to it.

**H.BACK** can be accessed from Level 1 or Level 2. To set the holdback value:

1. Press SROLL  button until display reads, "**H.back**".



2. Press the UP  or DOWN  button to set holdback value or to turn off holdback function.

## Creating a New Program or Editing an Existing Program

3216p is a 16 segment programmer consisting of eight ramp/ dwell pairs. Each ramp consists of a controlled rate of change of set point to a target level. Each ramp is followed by a dwell at that level. The ramp rate, target level and dwell time are set by the user.

The same steps are used when creating a new program and editing an existing program. A currently active program cannot be altered. Go into reset mode before starting to create or modify a program. Follow the steps below to create or edit a program.

1. '**PROG**' can be accessed from level 1 or Level 2.
2. Press the SCROLL  button until you reach the program parameter '**PROG**'

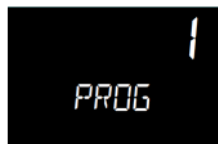

3. Press the UP  or DOWN  button to select a number for a new program or to edit an existing program. The scrolling display shows “CURRENT PROGRAM NUMBER”.





## End Type parameter

The action which occurs at the end of program or in reset depends on the configuration of the ‘END.T’ parameter. The ‘END.T’ can be:

**dwEll** : Controls at last program setpoint.

**SP2** : Controls at setpoint 2 (When the programmer completes the target setpoint will switch to setpoint 2. The setpoint 2 may be a lower or a higher temperature).

**rES** : Reset on completion and reverts to SP1 or SP2, based on the Setpoint selection.

Scroll  through parameters in Level 2 and set the required ‘END.T’ by pressing  or .

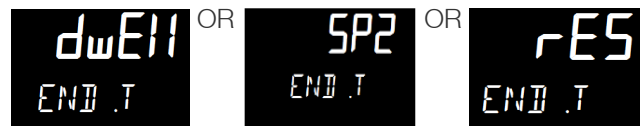

## To Configure the Programmer

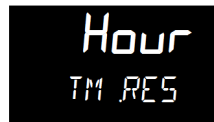

1. Enter level 2: refer to section “To Enter Level 2” for steps to enter Level 2.
2. To select the Programmer, press  as many times as necessary to view ‘PROG’.





3. To configure the first Program, press DOWN  or UP  to select program number ‘1’.





Similarly you can configure program (1, 2, 3, 4 or 5) for configuration.

4. To set the ramp unit, press SCROLL  button to select '**RAMP.U**' and then press DOWN  or UP  button to select **hour, min or sec** (In this example the ramp unit is set in min).





5. To set the Dwell unit, press SCROLL  button to select '**DWEL.U**' and then Press  or  to select **hour or min** (In this example the dwell unit is set in min).



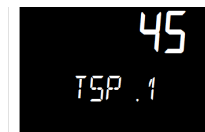

6. To set the first Target Set point, press SCROLL  button to select '**TSP.1**'. Then Press DOWN  or UP  button to set the value.

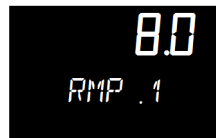

7. To set the first Ramp rate, press SCROLL  button to select '**RMP.1**'. Press DOWN  or UP  button to set the value.



8. To set the first Dwell, press SCROLL  button to select '**DWEL.1**'. Press DOWN  or UP  button to set the value.

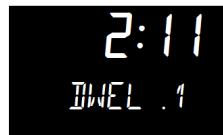







9. Now repeat the above three steps (6, 7 & 8) to set remaining all segments.

#### NOTE

- If not all the segments are used for a program, the Ramp & Dwell of each of the subsequent Segments should be set to OFF.
- A program will end in one of two ways, either revert to the control Set Point or dwell at the temperature set in the last segment used. When a program finishes on a dwell and the dwell time expires the temperature will revert to the control set point.
- Before running a program ensure that the control set point is set to Zero to avoid unexpected heating at the end of the program.
- When a Holdback is set, each segment used must have a Ramp Rate assigned to it, in order for it to be recognized by the program.

## To Operate the Programmer

Operation	Action	Indication
To Run a program	Press and quickly release  + 	Beacon RUN = On Scrolling display - CURRENT PROGRAM STATE
To Hold a program	Press and quickly release  + 	Beacon RUN = Flashing Scrolling display - PROGRAM HOLD
To Reset a program	Press and hold  +  for more than 1 second	If program has ended then 'PROGRAM END' will be displayed at the end of the program

Programs can also be operated from the 'P.STAT' parameter found in the level 1 parameter list.



### NOTE

- The program ramp rate is designed to reduce the heating rate or cooling rate that the furnace normally exhibits. When not using this feature, the furnace will operate at its maximum heating and cooling capability.
- When the program ramp has ended or has been reset, the furnace will continue to maintain set point temperature. It will not cool to ambient temperature unless the set point is set to ambient temperature by the program or by the operator.
- When a step change is required, the ramp rate should be set to 'OFF'.
- Where ramp/dwell pairs are not required, the ramp rate should be set to 'OFF' and the target set point, TSP, the same as the preceding segment.
- END TYPE - when the end type is SP2, Timer END does not occur until the ramp is complete or SP2 is achieved. It is more usual to use a DWELL (default) or RESET end type.



## Communication Option

The factory installed optional RS 485 Digital Communications Port allows controller to be connected to a PC for remote monitoring and control of the furnace. The equipment with communication option (COM) is equipped with two DB9 serial ports (1 Male port & 1 Female port). These ports are intended for connection to the PC or a Laptop & making a communication chain of furnace with communication option (COM) Capability. The RS 485 communication allows multiple devices (up to 30) to communicate at half-duplex on a single pair of wires, plus a ground wire..

NOTE The RS 485 pin should match with your DB9 to USB or 232 adapters for the communication option to work.

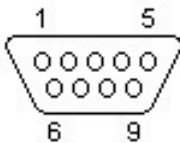
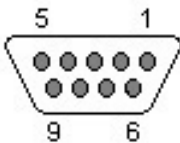
Furnace DB9-Pinout	RS 485 Output	DB-9 Male	DB-9 Female
Pin 2	A / D-		
Pin 3	B / D+		
Pin 5	Ground		

### Adapters - RS 485 to RS 232/USB

The communication option requires an RS 485 to USB Adapter or RS 485 to RS 232 Adapter to for the furnace to communicate with the PC or Laptop. The RS 485 to USB or RS 485 to RS 232 adapter with terminal block is recommended for free wire connections. RS 485 adapter is suggested as pin connections vary with different adapter manufacturers and may not work properly if they don't match with the above DB9 pinout of the furnace.

NOTE Please ensure the adapter is compatible with the operating system of your PC/Laptop. Some adapter needs driver softwares & port access privileges on your PC/Laptop for proper functioning. Please contact your local IT for assistance.

NOTE Contact Thermo Fisher Scientific for availability for serial cable connections

### Host Computer & Software

The host computer can communicate with furnaces with communication option (COM). A data logging & control software is required for data logging & control of the furnace using the RS 485 communication. Thermo Fisher Scientific does not provide any software - please refer to specialized software suppliers like SpecView or Eurotherm. These softwares can communicate with either a single Furnace or a network of several Furnaces with the communication option.

## Controller Parameters for Communication

Table 4 Controller Parameters for Communication

Parameter	Value
Comms Module Identity	Comms (67)
Communications Protocol	Modbus
Communication Interface	RS 485
Baud Rate	9600_baud (0)
Parity	none
Comms Address	1

### Troubleshooting Communications

If your connection is not working properly, check the following conditions:

- A. Verify complete and tight cable connections between the furnace and the PC.
- B. Verify that power has been supplied to the unit and temperature controller before starting the software program.
- c. Verify DB-9 pin connections as shown in wiring diagram, interchange 2 & 3 connections if communication is not working.
- d. Verify the configuration values in the controller, listed in the Table 4, "Controller Parameters for Communication".

# Maintenance & Cleaning



**CAUTION :** Maintenance should only be performed by trained personnel.



**WARNING :** Disconnect furnace from main power before attempting any maintenance to furnace or its controls.



**WARNING :** Use appropriate Personal Protective Equipment (PPE) per local protocols.



**WARNING :** When installing, maintaining, or removing the refractory insulation, the following precautions will minimize airborne dust and ceramic fiber:

- Keep personnel not involved in maintenance out of the area.
- Use a good vacuum to clean area and equipment. Do not use compressed air.
- Use NIOSH high efficiency respirator (3M #8710 or equivalent).
- Wear long sleeve clothing, gloves, hat, and eye protection to minimize skin and eye contact. Do not wear contact lenses.
- Thoroughly wash self after work is complete. Launder work clothing separate from other clothes and thoroughly clean laundering equipment after use. If clothing contains a large amount of dust and/or ceramic fiber, dispose of rather than clean.
- Promptly place used ceramic fiber parts and dust in plastic bags and dispose of properly.

For replacement parts specifications, refer to Chapter 11 “Replacement Parts” . For wiring schematics, refer to Chapter 10 “Wiring Diagram” .

## Cleaning and Decontamination

Furnace must be kept clean in order to ensure proper operation. Cleaning routine should be started with furnace at room temperature.

1. Vacuum the chamber to remove dust/debris, if needed.
2. Clean/Disinfect all exterior surfaces with a general-use laboratory disinfectant, such as quaternary ammonium. Rinse thoroughly with sterile distilled water, then 70% alcohol. Dry with a clean cloth as needed. Be sure not to spray any liquids directly on electronics, controls, and ceramic insulating materials or heating elements.
3. Ensure the upper exhaust port is free of any soot buildup. A pipe cleaner or stiff wire can be used to clean out the exhaust port.
4. Interior Surfaces Cleaning: Do not use any liquids on ceramic insulating materials or heating elements.

- a. Organic contaminants may be removed by burning them out. Refer to section “Initial Furnace Start-Up/Drying-Out Process” to do this.
- b. Inorganic contaminants may embed themselves into the ceramic insulating materials and heating elements. Recommend replacement. Contact Technical Service for further use or replacement.

## Thermocouple Replacement

**NOTE** For optimal performance, the thermocouple should be replaced once a year. In some situations a more frequent replacement schedule is warranted. SnSr or Sbr on the controller display indicates a broken thermocouple.

Refer to Figure 6 “Thermocouple Replacement” as you perform the following procedure:

1. Remove any atmosphere piping connected to the gas inlet tube assembly (item #2 in Figure 6).
2. Remove the two screws from the gas inlet tube assembly. Pull the gas inlet tube assembly straight out of the furnace.



**CAUTION :** Failure to pull the gas inlet tube assembly straight out of the furnace will result in damage to the gas inlet tube assembly or the heating unit.

3. Remove the screws from rear panel comers. Remove the rear panel (item # 1 in Figure 6).
4. Note polarity and wire location. Loosen the terminal screws and remove thermocouple lead wires.
5. Remove thermocouple mounting screws.
6. Slide out head and old thermocouple (item #3 in Figure 6).
7. Replace the thermocouple and connect new wires. Be careful not to bend the thermocouple wire. Red is always negative.
8. Replace the furnace rear panel.

9. Replace the gas inlet tube assembly.

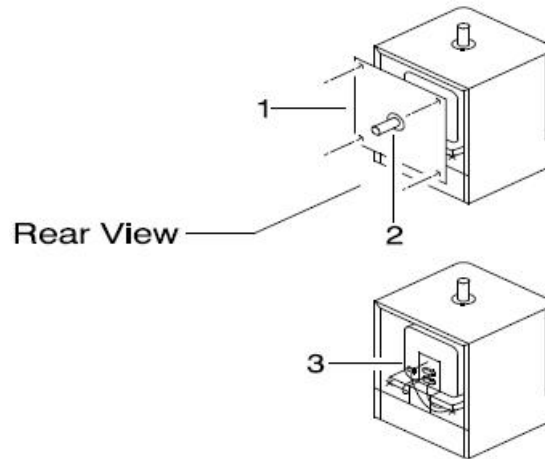

Figure 6 Thermocouple Replacement

## Solid-State Relay Replacement

If the SSR is inoperable, complete the following steps to replace the relay (refer to Figure 7 “Solid Relay Replacement”):

1. Remove the screws located on the left and right sides of the control panel (item #1 in Figure 7).
2. Slide the panel assembly away from the unit to expose components.
3. Locate the SSR on the component tray (item #2 in Figure 7).
4. Note the terminal connections of the relay wires and label them for reattachment. Remove the wires from the terminals of the relay.
5. Remove the mounting screws from the relay.
6. Replace the relay and reconnect the wires.

7. Reassemble the unit.

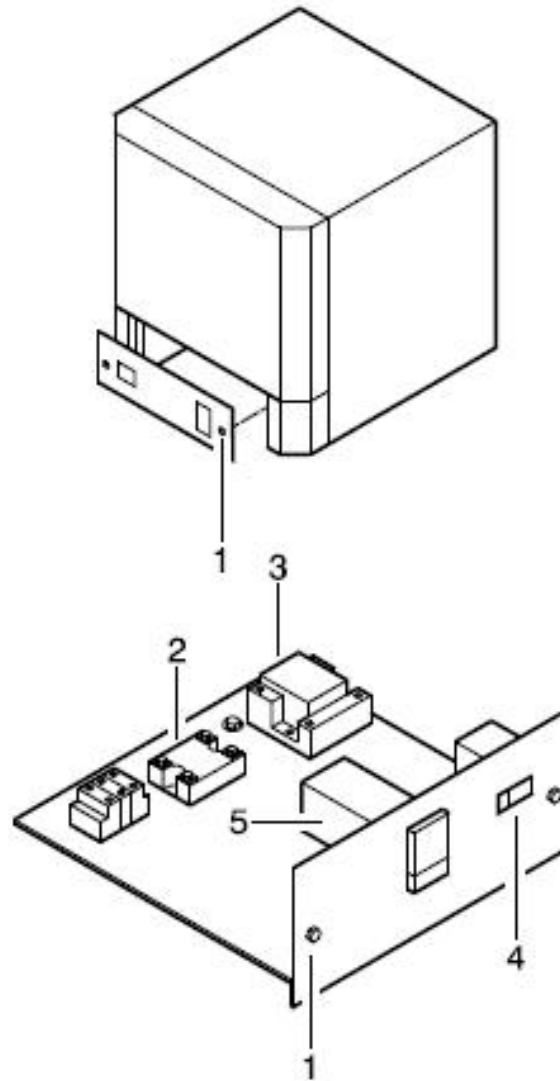

Figure 7 Solid Relay Replacement

## Contactor Replacement

If the contactor is inoperable, complete the following steps to replace the relay (refer to Figure 7 “Solid Relay Replacement”):

1. Remove the screws located on the left and right sides of the control panel (item #1 in Figure 7).
2. Slide the panel assembly away from the unit to expose components.
3. Locate the contactor on the component tray (item #3 in Figure 7).
4. Note the terminal connections of the relay wires and label them for reattachment. Remove the wires from the terminals of the relay.
5. Remove the mounting screws from the relay.

6. Replace the relay and reconnect the wires.
7. Reassemble the unit.

## Temperature Controller Replacement

To replace the entire controller, complete the following steps (refer to Figure 7 “Solid Relay Replacement”):

1. Remove the two sheet metal screws located on each side of the furnace near the lower front (#1 in Figure 7). Pull the control panel forward to access the controller (#5 in Figure 7).
2. Note the terminal connections of the wires and label them for reattachment. Remove power input and output wires from the back of the controller. Observe polarity for the thermocouple lead wire. Red is always negative. Refer to Figure 2 “Thermocouple” for additional wiring information.
3. Remove the retaining clamp.
4. Pull the controller out through the front of the control panel.
5. Install the replacement instrument by reversing the above procedure.

## Door Insulation Replacement

To replace the door insulation, complete the following steps (refer to Figure 8 “Door Insulation Replacement”):

1. Open the door completely.
2. Pull out the door insulation plug and frame up and out at a 45° angle.
3. Install the new door insulation plug and frame.

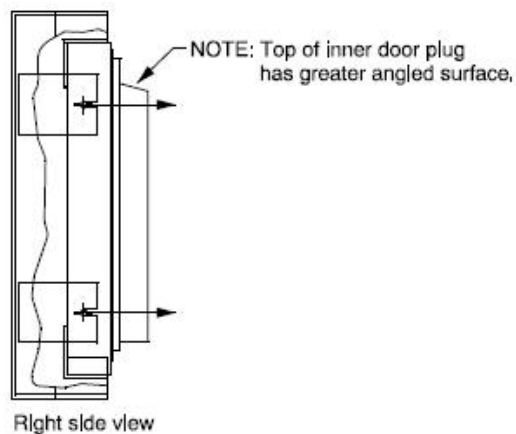

Door Insulation Replacement

Figure 8 Door Insulation Replacement

## Heating Unit Replacement

- May be irritating to skin, eyes, and respiratory tract.
- May be harmful if inhaled.
- May contain or form cristobalite (crystalline silica) with use at high temperature (above 871°C (1599.8°F)) which can cause severe respiratory disease.
- Possible cancer hazard based on tests with laboratory animals. Animal studies to date are inconclusive. No human exposure studies with this product have been reported.

To replace the heating unit, complete the following steps (refer to Figure 9 “Heating Unit Replacement”):

1. Remove any atmosphere piping connected to the gas inlet tube assembly (item #2 in Figure 9).
2. Remove the two screws from the gas inlet tube assembly. Pull the gas inlet tube assembly straight out of the furnace.



**CAUTION :** Failure to pull the gas inlet tube assembly straight out of the furnace will result in damage to the gas inlet tube assembly or the heating unit.

3. Remove the screws from corners of the rear panel (#1 in Figure 9).
4. Remove the rear panel to expose the heating unit assembly.
5. Remove the two screws from the exhaust vent. Pull the exhaust vent straight up and out of the furnace.
6. Remove the six corner screws from the shell (#3 in Figure 9).
7. Lift the shell away from the base of the cabinet to expose the entire heating unit.
8. Note the terminal connections of the element wires and label them for reattachment. Loosen the terminal nuts and remove the element wires (#4 in Figure 9).
9. Remove the thermocouple head screws and slide the thermocouple out (#5 in Figure 9).
10. Unhook the spring bands from the base of the chassis.



11. Replace the heating unit and reassemble the furnace.

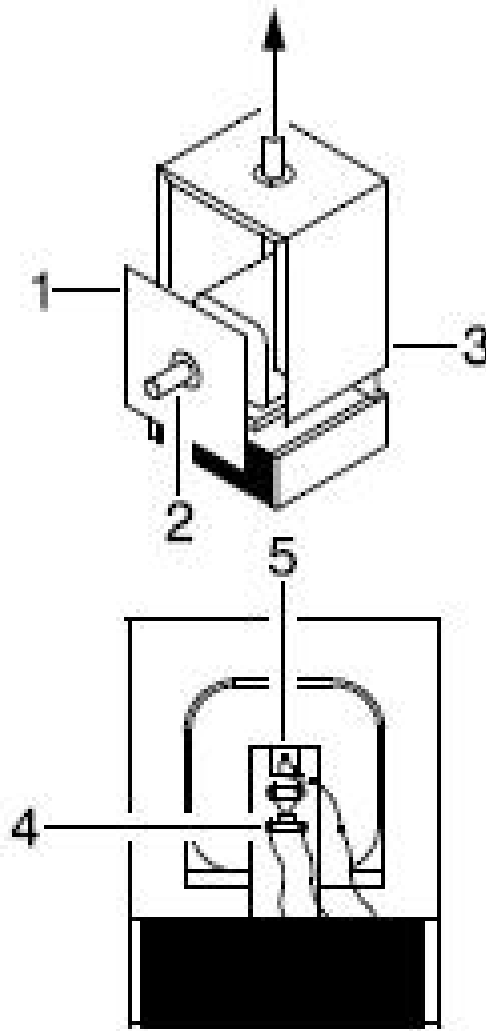

Figure 9 Heating Unit Replacement



# Troubleshooting



**DANGER :** Troubleshooting procedures involve working with high voltages which can cause injury or death. Troubleshooting should only be performed by trained personnel. This section is a guide to troubleshooting controller and furnace problem.

Table 5 Eurotherm 3216 Controller Troubleshooting

Problem	Probable Cause	Solution
Etun	Auto tune cannot be performed.	Check whether program or timer is running, If yes Turn off Programmer or Timer. Turn off Auto tune & Turn on again The error will be resolved, if still problem persist contact your supplier.
ECAL	Calibration error	Re-instate factory calibration.
E2.Er	EEPROM error	Return to factory for repair.
EE.Er	Non-vol memory error	Note the error and contact your supplier.
E.Lin	Invalid input type. This refers to custom linearization which may not have been applied correctly or may have been corrupted.	Return to factory for repair.
The controller displays do not illuminate.	The furnace is not connected to the power supply.	Check furnace connection to power source.
	Main switch is defective.	Replace power switch or controller.
	One of two circuit breakers is tripped.	If you find the breaker tripped first try to reset it by pressing the button in. If the breaker is not tripped and will not reset it should be replaced. Ensure both breakers are reset.

Table 6 Furnace Troubleshooting

Problem	Solution
Furnace temperature runs away.	<p>Check solid-state relay:            Disconnect controller source to solid state relay.            Connect power to furnace. If the heating unit heats, replace the solid-state relay.</p>
Furnace does not heat.	<p>Front panel red indicator light is on:            If the controller run or local light is off, check that the setpoint temperature is higher than the furnace display temperature.            If the controller run or local light is on, disconnect power from the furnace and check the heating element for continuity.</p>
	<p>Front panel red indicator light is off:            Check that the power switch is on.            Check that the indicator lights on the controller display are on.            Check that the furnace door is fully closed.            Check that the door interrupt switch is engaged when the furnace door is fully closed.            Check the electrical wires for visible damage.            Replace the electrical wires if necessary.            Check that the deviation high alarm setpoint on the controller is set higher than the operating temperature.</p>

# Wiring Diagram

The following pages contain the wiring schematics for the 1100°C box furnace series.

304232104

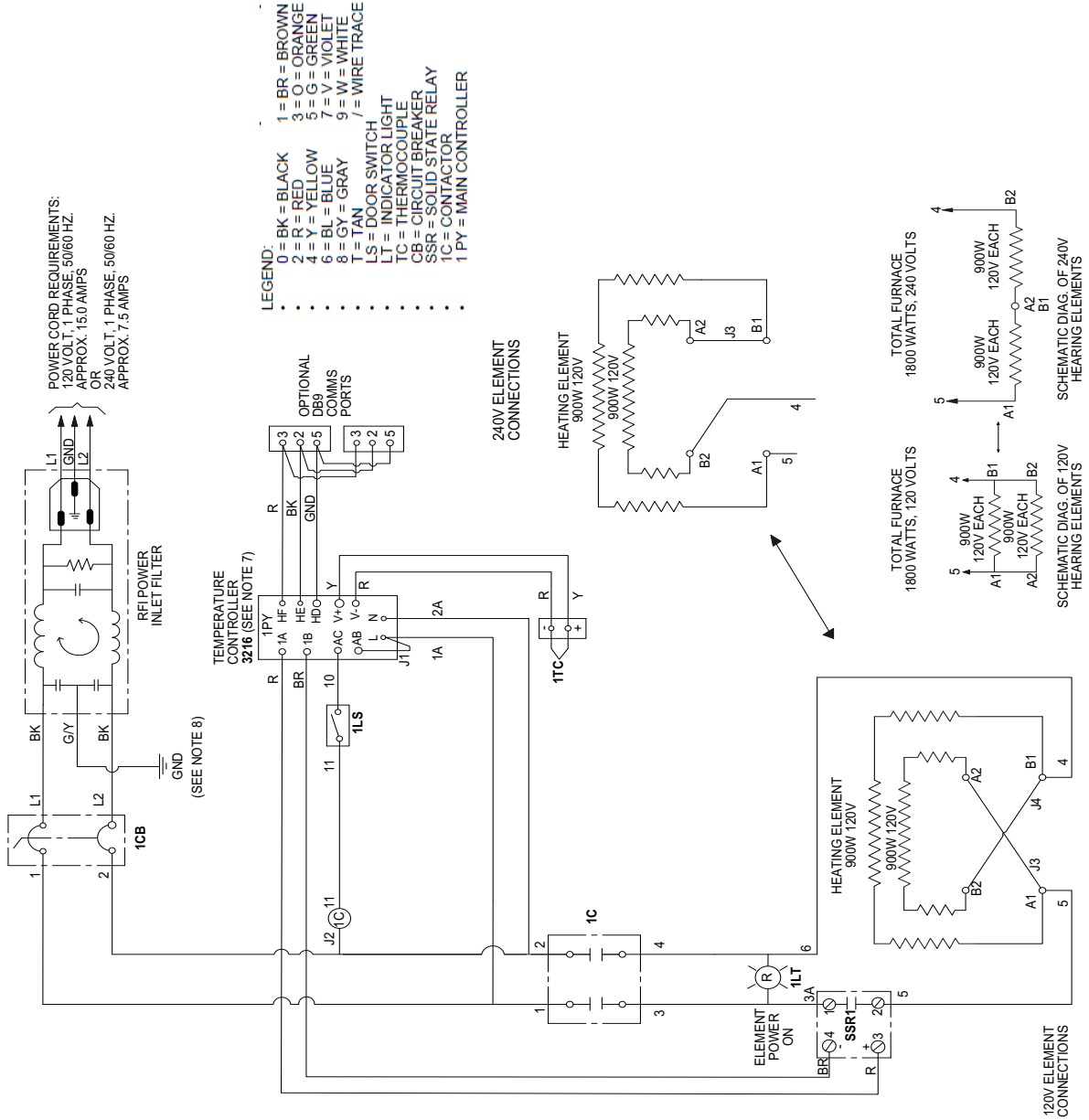

Figure 10 Wiring Diagram (BF51748, BF51766, BF51848 & BF51866)

# 304232105

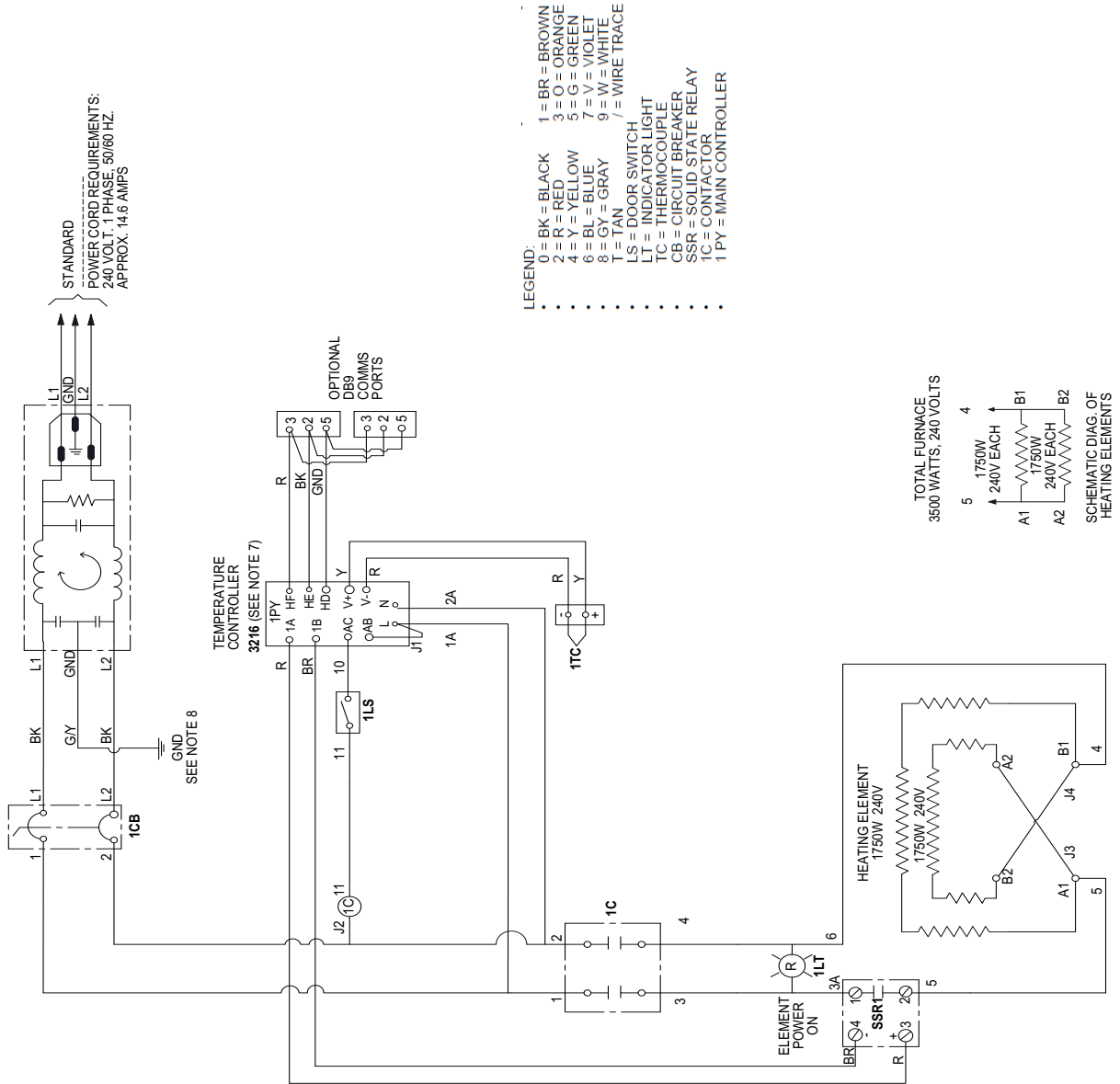

Figure 11 Wiring Diagram (BF51794, BF51894)

# 304232106

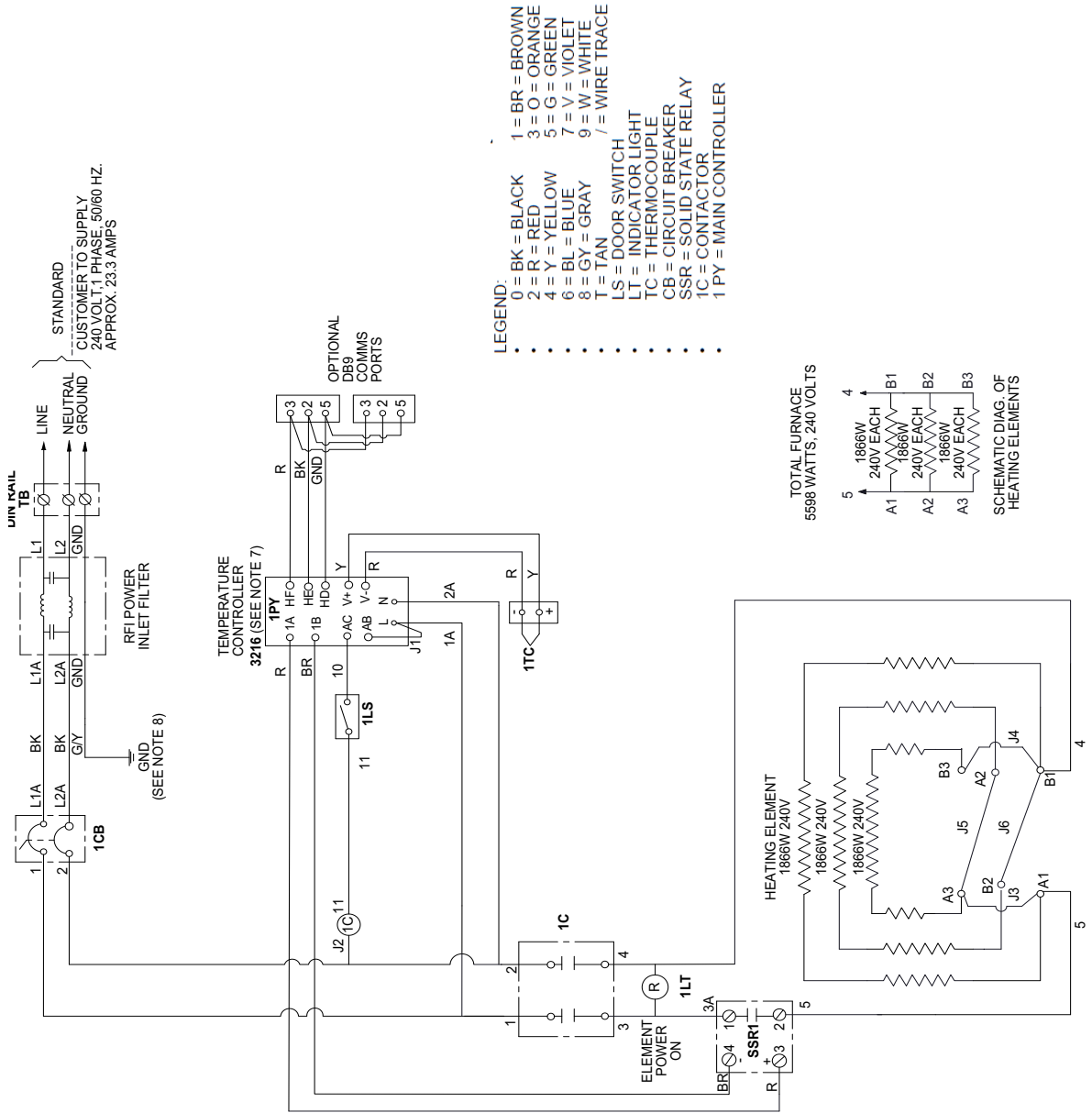

Figure 12 Wiring Diagram (BF51728, BF51828)





# Detachable Power Cord Options

Table 7. Detachable Power Cord Options

Country	Voltage	Max Amps	Compliance	Plug Type	Part#
NORTH AMERICA*	125	20	cULus	NEMA 5-20P	311373H02
NORTH AMERICA**	250	20	cULus	NEMA 6-20P	311373H03
EUROPE / SOUTH KOREA**	250	16	VDE ,KEMA, KTL, KC	CEE 7/7 Schuko	311373H01
China	250	16	CCC	GB2099.1-1 996	316705H02
UK, Singapore, Malaysia, Ireland, Hong Kong, Saudi Arabia, Sri Lanka, Bahrain	250	13	BSI	BS1363	316704H01
India	250	16	STQC/BIS	BS546	430271H01
Australia	250	15	SAA	Type 3112	430268H01
Switzerland	250	16	SEV	SEV 1011	430382H01
Italy	250	16	IMQ	CEI 23-16	430272H01
Argentina	250	16	IRAM	IRAM 2073	430381H01
Brazil	250	16	INMETRO	NBR14136	430383H01

\*Included with 1.9 L and 5.3 L units

\*\*Included with 1.9 L, 5.3 L, and 18.4 L units



# Replacement Parts

Table 8 Model BF51748, Box Furnaces, 1100°C

Description	Item	BF51748A-1	BF51748C-1	BF51748COMA-1
Heater – chamber assembly	310766H01	1	1	1
Terminal block, element	7218-2054-00AS	2	2	2
Hearth plate	7011-2022-00B	1	1	1
Exhaust port cover	7221-2063-00A	1	1	1
Gas inlet assembly	300253G04 S	1	1	1
Thermocouple assembly	7299-1186-00E S	1	1	1
T/C lead wire	33940-002	4 feet	4 feet	4 feet
Wire harness	38850G01	1	1	1
Power cord, 120 VAC	311373H02	1	N/A	1
Power cord, 240 VAC	311373H03 (NEMA) &	N/A	1	N/A
	311373H01 (European)	N/A	1	N/A
Main circuit breaker	302795H03	1	1	1
Contactor, 120 VAC	16869	1	N/A	1
Contactor, 240 VAC	16934	N/A	1	N/A
Solid state relay	102460	1	1	1
Red pilot light, 120 VAC	33002-002	1	N/A	1
Red pilot light, 240 VAC	33002-001	N/A	1	N/A
Controller	CN71X301	1	1	N/A
	CN71X302	N/A	N/A	1
Door insulation assembly	304747H01	1	1	1
Door switch	38258H01 & 38259H01	1	1	1
Door catch/latch	32828H01	1	1	1
Operation manual	330985H01	1	1	1
COMMS male end cable	303402G01	N/A	N/A	1
COMMS female end cable	303402G02	N/A	N/A	1
Screwlock kit	740-0039	N/A	N/A	4
Power entry connector	311328H01	1	1	1

Table 9 Model BF51766 Series, Box Furnaces, 1100°C

Description	Item	BF51766A-1	BF51766C-1	BF51766COMA-1
Heater – chamber assembly	310766H01	1	1	1
Terminal block, element	7218-2054-00A S	2	2	2
Hearth plate	7011-2022-00C	1	1	1
Exhaust port cover	7221-2063-00A	1	1	1
Gas inlet assembly	300253G02 S	1	1	1
Thermocouple assembly	7299-1186-00E S	1	1	1
T/C lead wire	33940-002	6 feet	6 feet	6 feet
Wire harness	38850G01	1	1	1
Power cord, 120 VAC	311373H02	1	N/A	1
Power cord, 240 VAC	311373H03 (NEMA)	N/A	1	N/A
	311373H01 (European)	N/A	1	N/A
Main circuit breaker	302795H03	1	1	1
Contactor, 120 VAC	16869	1	N/A	1
Contactor, 240 VAC	16934	N/A	1	N/A
Solid state relay	102460	1	1	1
Red pilot light, 120 VAC	33002-002	1	N/A	1
Red pilot light, 240 VAC	33002-001	N/A	1	N/A
Controller	CN71X301	1	1	N/A
	CN71X302	N/A	N/A	1
Door insulation assembly	302025H01	1	1	1
Door switch	38258H01 & 38259H01	1	1	1
Door catch/latch	32820H01	1	1	1
Operation manual	330985H01	1	1	1
COMMS male end cable	303402G01	N/A	N/A	1
COMMS female end cable	303402G02	N/A	N/A	1
Screwlock kit	740-0039	N/A	N/A	4
Power entry connector	311328H01	1	1	1

Table 10 Model BF51794 Series Box Furnaces, 1100°C

Description	Item	BF51794C-1
Heater – chamber assembly	310768H01	1
Terminal block, element	7218-2054-00A S	2
Hearth plate	7011-2051-00A	1
Exhaust port cover	7221-2063-00A	1
Gas inlet assembly	300253G02 S	1
Thermocouple assembly	7299-1186-00A S	1
T/C lead wire	33940-002	8 feet
Wire harness	38850G03	1
Power cord	311373H01 (European)	1
	311373H03 (NEMA)	1
Main circuit breaker	302795H03	1
Contactors	16934	1
Solid state relay	102460	1
Red pilot light, 120 VAC	33002-001	1
Controller	CN71X301	1
Door insulation assembly	300837H01	1
Door switch	38258H01 & 38259H01	1
Door catch/latch	38280H01	1
Operation manual	330985H01	1
Power entry connector	311328H01	1

Table 11 Model BF51728 Series Box Furnaces, 1100 °C

Description	Item	BF51728C-1 BF51728RHDC-1
Heater – chamber assembly	301230H01	1
Terminal block, element	7218-2054-00A S	3
Bracket, terminal block	35024H01	1
Hearth plate	7011-2066-00A	1
Exhaust port cover	7221-2063-00A	1
Gas inlet assembly	300253G02 S	1
Thermocouple assembly	7299-1186-00A S	1
T/C lead wire	33940-002	8 feet
Wire harness	38850G04	1
Main circuit breaker	302795H03	1
Contactors	16868	1
Solid state relay	102460	1
Red pilot light, 120 VAC	33002-001	1
Controller	CN71X301	1
Door insulation assembly	304050H01	1
Door switch	38258H01 & 38259H01	1
Door catch/latch	16042	2
Operation manual	330985H01	1

Table 12. Model BF51848, Box Furnaces, 1100°C

Description	Item	BF51848A-1	BF51848C-1	BF51848COMA-1	BF51848COMC-1
Heater – chamber assembly	310766H01	1	1	1	1
Terminal block, element	7218-2054-00A S	2	2	2	2
Hearth plate	7011-2022-00B	1	1	1	1
Exhaust port cover	7221-2063-00A	1	1	1	1
Gas inlet assembly	300253G04 S	1	1	1	1
Thermocouple assembly	7299-1186-00E S	1	1	1	1
T/C lead wire	33940-002	4 feet	4 feet	4 feet	4 feet
Wire harness	38850G01	1	1	1	1
Power cord, 120 VAC	311373H02	1	N/A	1	N/A
Power cord, 240 VAC	311373H03 (NEMA)	N/A	1	N/A	1
	311373H01 (European)	N/A	1	N/A	1
Main circuit breaker	302795H03	1	1	1	1
Contactors, 120 VAC	16869	1	N/A	1	N/A
Contactors, 240 VAC	16934	N/A	1	N/A	1
Solid state relay	102460	1	1	1	1
Red pilot light, 120 VAC	33002-002	1	N/A	1	N/A
Red pilot light, 240 VAC	33002-001	N/A	1	N/A	1
Controller	CN71X303	1	1	N/A	1
	CN71X304	N/A	N/A	1	N/A
Door insulation assembly	304747H01	1	1	1	1
Door switch	38258H01 & 38259H01	1	1	1	1
Door catch/latch	32828H01	1	1	1	1
Operation manual	330985H01	1	1	1	1
COMMS male end cable	303402G01	N/A	N/A	1	N/A
COMMS female end cable	303402G02	N/A	N/A	1	N/A
Screwlock kit	740-0039	N/A	N/A	4	N/A
Power entry connector	311328H01	1	1	1	1

Table 13. Model BF51866 Series, Box Furnaces, 1100°C

Description	Item	BF51866A-1	BF51866C-1	BF51866COMA-1
Heater – chamber assembly	310766H01	1	1	1
Terminal block, element	7218-2054-00A S	2	2	2
Hearth plate	7011-2022-00C	1	1	1
Exhaust port cover	7221-2063-00A	1	1	1
Gas inlet assembly	300253G02 S	1	1	1
Thermocouple assembly	7299-1186-00E S	1	1	1
T/C lead wire	33940-002	6 feet	6 feet	6 feet
Wire harness	38850G01	1	1	1
Power cord, 120 VAC	311373H02	1	N/A	1
Power cord, 240 VAC	311373H03 (NEMA)	N/A	1	N/A
	311373H01 (European)	N/A	1	N/A
Main circuit breaker	302795H03	1	1	1
Contactors, 120 VAC	16869	1	N/A	1
Contactors, 240 VAC	16934	N/A	1	N/A
Solid state relay	102460	1	1	1
Red pilot light, 120 VAC	33002-002	1	N/A	1
Red pilot light, 240 VAC	33002-001	N/A	1	N/A
Controller	CN71X303	1	1	N/A
	CN71X304	N/A	N/A	1
Door insulation assembly	302025H01	1	1	1
Door switch	38258H01 & 38259H01	1	1	1
Door catch/latch	32820H01	1	1	1
Operation manual	330985H01	1	1	1
COMMS male end cable	303402G01	N/A	N/A	1
COMMS female end cable	303402G02	N/A	N/A	1
Screwlock kit	740-0039	N/A	N/A	4
Power entry connector	311328H01	1	1	1



Table 14. Model BF51894 Series Box Furnaces, 1100°C

Description	Item	BF51894C-1
Heater – chamber assembly	310768H01	1
Terminal block, element	7218-2054-00A S	2
Hearth plate	7011-2051-00A	1
Exhaust port cover	7221-2063-00A	1
Gas inlet assembly	300253G02 S	1
Thermocouple assembly	7299-1186-00A S	1
T/C lead wire	33940-002	8 feet
Wire harness	38850G03	1
Power cord	311373H01 (European)	1
	311373H03 (NEMA)	1
Main circuit breaker	302795H03	1
Contactors	16934	1
Solid state relay	102460	1
Red pilot light, 120 VAC	33002-001	1
Controller	CN71X303	1
Door insulation assembly	300837H01	1
Door switch	38258H01 & 38259H01	1
Door catch/latch	38280H01	1
Operation manual	330985H01	1
Power entry connector	311328H01	1

Table 15. Model BF51828 Series Box Furnaces, 1100 °C

Description	Item	BF51828C-1 BF51828RHDC-1	BF51828COMC-1
Heater – chamber assembly	301230H01	1	1
Terminal block, element	7218-2054-00A S	3	3
Bracket, terminal block	35024H01	1	1
Hearth plate	7011-2066-00A	1	1
Exhaust port cover	7221-2063-00A	1	1
Gas inlet assembly	300253G02 S	1	1
Thermocouple assembly	7299-1186-00A S	1	1
T/C lead wire	33940-002	8 feet	8 feet
Wire harness	38850G04	1	1
Main circuit breaker	302795H05	1	1
Contactors	16868	1	1
Solid state relay	102460	1	1
Red pilot light, 120 VAC	33002-001	1	1
Controller	CN71X303	1	1
Door insulation assembly	304050H01	1	1
Door switch	38258H01 & 38259H01	1	1
Door catch/latch	16042	2	2
Operation manual	330985H01	1	1
COMMS Male end cable	303402G01	N/A	1
COMMS Female end cable	303402G02	N/A	1
Screwlock Kit	740-0039	N/A	4

## End of Life Care

Be sure to follow local regulations when disposing of any unit. Some additional suggestions are listed below:

- Be sure to clean up any biological safety hazards
- Have a certified technician remove the insulation from the unit then dispose per SDS and local laws and regulations.

## WEEE Compliance

**WEEE Compliance.** This product is required to comply with the European Union's Waste Electrical & Electronic Equipment (WEEE) Directive 2012/19/EU. It is marked with the following symbol. Thermo Fisher Scientific has contracted with one or more recycling/disposal companies in each EU Member State, and this product should be disposed of or recycled through them. Further information on our compliance with these Directives, the recyclers in your country, and information on Thermo Scientific products which may assist the detection of substances subject to the RoHS Directive are available at [www.thermofisher.com/](http://www.thermofisher.com/)

**WEEE Konformität.** Dieses Produkt muss die EU Waste Electrical & Electronic Equipment (WEEE) Richtlinie 2012/19/EU erfüllen. Das Produkt ist durch folgendes Symbol gekennzeichnet. Thermo Fisher Scientific hat Vereinbarungen getroffen mit Verwertungs-/Entsorgungsanlagen in allen EU-Mitgliedstaaten und dieses Produkt muss durch diese Firmen wiederverwertet oder entsorgt werden. Mehr Informationen über die Einhaltung dieser Anweisungen durch Thermo Scientific, die Verwerter und Hinweise die Ihnen nützlich sein können, die Thermo Fisher Scientific Produkte zu identifizieren, die unter diese RoHS-Anweisung fallen, finden Sie unter [www.thermofisher.com/](http://www.thermofisher.com/)

**Conformità WEEE.** Questo prodotto deve rispondere alla direttiva dell'Unione Europea 2012/19/EU in merito ai Rifiuti degli Apparecchi Elettrici ed Elettronici (WEEE). Marcato col seguente simbolo. Thermo Fisher Scientific ha stipulato contratti con una o diverse società di riciclaggio/smaltimento in ognuno degli Stati Membri Europei. Questo prodotto verrà smaltito o riciclato tramite queste medesime. Ulteriori informazioni sulla conformità di Thermo Fisher Scientific con queste Direttive, l'elenco delle ditte di riciclaggio nel Vostro paese e informazioni sui prodotti Thermo Scientific che possono essere utili alla rilevazione di sostanze soggette alla Direttiva RoHS sono disponibili sul sito <http://www.thermofisher.com/>

**Conformité WEEE.** Ce produit doit être conforme à la directive euro-péenne (2012/19/EU) des Déchets d'Équipements Électriques et Électroniques (DEEE). Il est marqué par le symbole suivant. Thermo Fisher Scientific s'est associé avec une ou plusieurs compagnies de recyclage dans chaque état membre de l'union européenne et ce produit devrait être collecté ou recyclé par celles-ci. Davantage d'informations sur la conformité de Thermo Fisher Scientific à ces directives, les recycleurs dans votre pays et les informations sur les produits Thermo Fisher Scientific qui peuvent aider la détection des substances sujettes à la directive RoHS sont disponibles sur <http://www.thermofisher.com/>

**Cumplimiento de WEEE.** Se requiere que este producto cumpla con la Directiva 2012/19/UE de Desechos de Equipos Eléctricos y Electrónicos (WEEE) de la Unión Europea. Está marcado con el siguiente símbolo. Thermo Fisher Scientific ha contratado a una o más empresas de reciclaje / eliminación en cada Estado miembro de la UE, y este producto debe desecharse o reciclarse a través de ellos. Para obtener más información sobre el cumplimiento de estas Directivas, los recicladores de su país e información sobre los productos Thermo Scientific que pueden ayudar a detectar sustancias sujetas a la Directiva RoHS, visite [www.thermofisher.com/](http://www.thermofisher.com/)

Great Britain



Deutschland



Italia



France



Spanish



# Contact Information

Thermo Fisher Scientific products are backed by a global technical support team ready to support your applications. Visit [www.thermofisher.com](http://www.thermofisher.com) or call:

Countries	Sales
North America	+1 866 984 3766
India toll free	1800 22 8374
India	+91 22 6716 2200
China	+800 810 5118, +400 650 5118
France	+33 2 2803 2180
Germany international	+49 6184 90 6000
Germany national toll free	0800 1 536 376
UK/Ireland	+44 870 609 9203

For countries not listed here, visit [www.thermofisher.com](http://www.thermofisher.com) and go to the Contact Us page under the Services menu to locate the contact information for your area.

Thermo Fisher Scientific Inc.  
275 Aiken Road  
Asheville, NC 28804  
United States





---

Find out more at [thermofisher.com](https://www.thermofisher.com)

**thermo**scientific